



Tandem 300 and Tandem 300 Ceiling Cassette Unit

► Assembly and Installation Instructions

Keep these instructions in a safe place for future use!



Kampmann.de/installation_manuals

[Kampmann.co.uk/installation_manuals](https://www.kampmann.co.uk/installation_manuals)

Kampmann GmbH
Friedrich-Ebert-Str. 128 - 130
49811 Lingen (Ems)
Germany

T +49 591 7108-660
F +49 591 7108-173
E export@kampmann.de
W [Kampmann.eu](https://www.kampmann.eu)

Kampmann UK Ltd.
Dial House, Govett Avenue
Shepperton, Middlesex, TW17 8AG
Great Britain

T +44 (0)1932 228592
F +44 (0)1932 228949
E info@kampmann.co.uk
W [Kampmann.co.uk](https://www.kampmann.co.uk)

KAMPMAN
Genau mein Klima.

Contents

▸ About these instructions	5
▸ Key to symbols	5
1 ▸ Intended use	6
2 ▸ Safety information	8
3 ▸ Transport and storage	9
4 ▸ Delivery	9
5 ▸ Installation	9
▸ 5.1.1 Tandem 300 model 12 - 30 with wall brackets	10
▸ 5.1.2 Tandem 300 model 12 - 30 with ceiling brackets	11
▸ 5.2.1 Tandem 300 ceiling cassette unit model 12 - 30 with wall brackets	12
▸ 5.2.2 Tandem 300 ceiling cassette unit model 12 - 30 with ceiling brackets	13
▸ 5.3 Tandem 300 extension	14
6 ▸ Hydraulic connections	15
▸ 6.1 Installation of the thermoelectric shut-off valve and outlet temperature limit valve	16
▸ 6.2 Installation of the remote sensor for outlet air temperature limit valve	17
▸ 6.3 Adjustment of the air outlet rectifier	17
7 ▸ Technical data	18
8 ▸ Commissioning	19
9 ▸ Maintenance	20
▸ 9.1 Tandem 300	20
▸ 9.2 Tandem 300 ceiling cassette units	23

10	Electrical wiring	25
▶ 10.1	Electromechanical model with internal fault signal processing (*00)	27
▶ 10.2	Electromechanical model with external fault signal processing (*T)	30
▶ 10.3	KaControl model (*C1)	33
▶ 10.3.1	Intended use	33
▶ 10.3.2	Operation of the KaController	34
▶ 10.3.2.1	Function keys, display elements	35
▶ 10.3.2.2	Operation	36
▶ 10.4	Alarm messages	45
▶ 10.5	KaController installation	46
▶ 10.5.1	Troubleshooting A11 – A17	47
▶ 10.6	Cabling	49
▶ 10.6.1	General information	49
▶ 10.6.2	KaController	49
▶ 10.6.3	External room temperature sensor	50
▶ 10.6.4	Inputs for processing external contacts (e.g. on-site BMS etc.)	50
▶ 10.6.5	Internal unit temperature sensor	50
▶ 10.7	Addressing – Single-circuit controls	51
▶ 10.8	Setting the unit configuration by means of DIP switches	52
▶ 10.9	Parameter settings	54
▶ 10.10	Parameter settings	55
▶ 10.10.1	Setting the absolute setpoint temperature or $\pm 3K$	55
▶ 10.10.2	ON/OFF, Eco/Day functions	56
▶ 10.10.3	Function of DI2	57
▶ 10.10.4	Function of digital outputs V1 and V2	58
▶ 10.10.5	Function of multifunctional inputs AI1, AI2 and AI3	59
▶ 10.11	Functional test of the connected assemblies	61
▶ 10.12	Parameter list for control PCB	62
▶ 10.13	KaController parameters	65
▶ 10.13.1	General	65
▶ 10.13.2	Calling up the Parameter menu	65
▶ 10.13.3	KaController parameter list	66

About these instructions

Carefully read these instructions in full prior to any assembly and installation work!

Anyone involved with the installation, commissioning and use of this product is obliged to pass these instructions on to tradespeople who are involved at the same time or subsequently, as well as to end users or operators. Retain these instructions until final decommissioning!

We reserve the right to make content or design-related changes without prior notice!

Key to symbols

Safety information



CAUTION! DANGER!

Non-compliance with this information can lead to serious personal injuries or damage to property.



IMPORTANT NOTE

Important note! We cannot guarantee the trouble-free operation of the unit(s) in the event of non-compliance.

1 ▶ Intended use

Kampmann Tandem 300 door air curtains are built in line with the state of the art and recognised safety regulations. Nevertheless their use can result in danger to people or damage to the unit or other material property if they are not properly installed or properly used.

Applications

Only use Tandem 300 door air curtains

- indoors (for example in offices, showrooms, department stores etc.)

Never use Tandem 300 door air curtains

- outdoors,
- in humid areas, such as swimming pools, in wet rooms,
- in areas where there is a risk of explosion,
- in areas with a high dust content,
- in areas with an aggressive atmosphere.

Protect the products from any moisture during installation. Check the application with the manufacturer in case of any doubt. Any use other than the use specified above is deemed not to be correct and proper. The operator of the unit is solely responsible for any damage arising as a result of this. Correct and proper use is deemed to include observing the installation instructions described in these instructions.

Specialist knowledge

The installation of this product requires specialist knowledge of heating, cooling, ventilation and electrical engineering. This knowledge, generally learned in vocational training in the fields mentioned in section 2, is not described separately. Damage caused by improper installation is the responsibility of the operator.

The installer of these units should have adequate knowledge of the following gained from specialist vocational training

- Safety and accident prevention regulations
- Guidelines and recognised technical regulations, i.e. Association of German Electricians (VDE) regulations, DIN and EN standards.

Limits of operation and use

Limits of operation		
Min./max. water temperature	°C	40 - 90
Min./max. air intake temperature	°C	6 - 40
Min./max. air humidity	%	15 - 75
Max. operating pressure	bar	10
Min./max. glycol percentage	%	25 - 50

We would refer to VDI-2035 Sheets 1 & 2, DIN EN 14336 and DIN EN 14868 with regard to the properties of the medium used to protect the equipment. The following values provide further guidance.

The water used should be free of contamination, such as suspended substances and reactive substances.

Water quality		
pH value*1		8 - 9
Conductivity*1	µS/cm	< 700
Oxygen content (O ₂)	mg/l	< 0.1
Hardness	°dH	4 - 8.5
Sulphur ions (S)		not measurable
Sodium ions (Na ⁺)	mg/l	< 100
Iron ions (Fe ²⁺ , Fe ³⁺)	mg/l	< 0.1
Manganese ions (Mn ²⁺)	mg/l	< 0.05
Ammonia ions (NH ⁴⁺)	mg/l	< 0.1
Chlorine ions (Cl)	mg/l	< 100
CO ₂	ppm	< 50
Sulphate ions (SO ₄ ²⁻)	mg/l	< 50
Nitrite ions (NO ₂ ⁻)	mg/l	< 50
Nitrate ions (NO ₃ ⁻)	mg/l	< 50

2 ▶ Safety information



Only allow a qualified electrician to perform installation, assembly and maintenance work on electrical units in compliance with VDE guidelines. Wiring should comply with the applicable VDE regulations and provisions laid down by the regional electricity providers.

Non-compliance with the regulations and operating instructions can result in the units malfunctioning with consequential damage and danger to people. There is a danger of fatal injury caused by wires being crossed due to incorrect wiring! Disconnect all parts of the system from the mains power supply and prevent them from being reconnected before starting any connection and maintenance work!

Please read these instructions in full to ensure correct and proper installation and the correct operation of Tandem 300 door air curtains.



Please note the following safety-relevant information:

- Disconnect all parts of the system that are being worked on. Ensure that the system cannot be accidentally re-connected!
- Before commencing installation/maintenance work, wait until the fan has come to a standstill after the unit has been switched off.
- **Caution!** Pipes, casings and fittings can become very hot depending on the operating mode!
- **Caution!** Wear gloves, safety shoes and suitable protective clothing when transporting the unit! Sharp edges cannot be ruled out despite care during manufacture.
- Use safe lifting platforms and scaffolding for installation!

Protect the products from any moisture during installation. Check the application with the manufacturer in case of any doubt. Any use other than the use specified above is deemed not to be correct and proper. The operator of the unit is solely responsible for any damage arising as a result of this. Correct and proper use is deemed to include observing the installation instructions described in these instructions.

Modifications to the unit

Do not undertake any modifications or upgrades to Tandem 300 door air curtains without discussing them with the manufacturer as they can impair the safety and operation of the unit. Do not carry out any measures on the unit not described in this manual. Ensure that all on-site systems and cabling are suitable for connection to the intended system!

3 ▶ Transport and storage

- Please note all applicable safety and accident prevention regulations.
- **Attention!** Risk of sharp edges! Wear gloves, safety shoes and suitable protective clothing during transportation!
- Two people are needed to carry the unit. Use suitable means of transport to avoid any damage to your health!

Store the units in dry, dust-free and weather-proof rooms without any temperature fluctuations.

- Never stack the units on top of each other to prevent damage to them!
- Use the original packaging for storage.

4 ▶ Delivery

Check immediately on receipt:

- Is the delivery damaged?
- Have the items ordered been delivered? Check model numbers.
- Is the delivery and number of items delivered correct?

5 ▶ Installation



Caution!

Ensure when suspending the unit that it is completely horizontal to ensure proper operation!

Allow sufficient space beside the unit (min. 30 cm recommended!) to fit and access the valves. Please note that both Tandem 300 and Tandem 300 model 30 ceiling cassette units require 3 brackets for fixing.

Dimensions of suspension points

Unit				
Model	12	20	25	30
Dimension A (mm)	980	1730	2230	2 x 1365

5.1.2 Tandem 300 model 12 - 30 with ceiling brackets

Front view

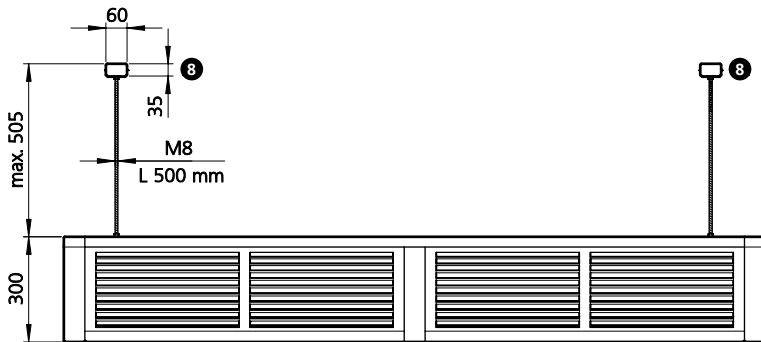

Side view

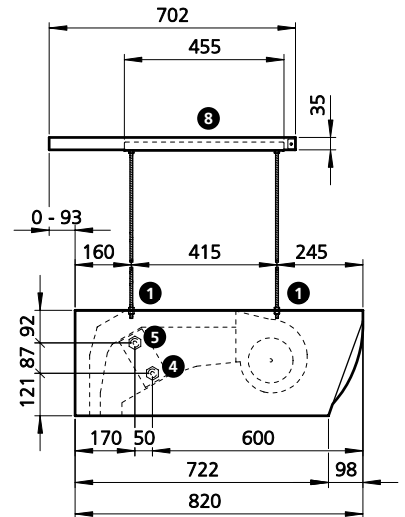

Plan view

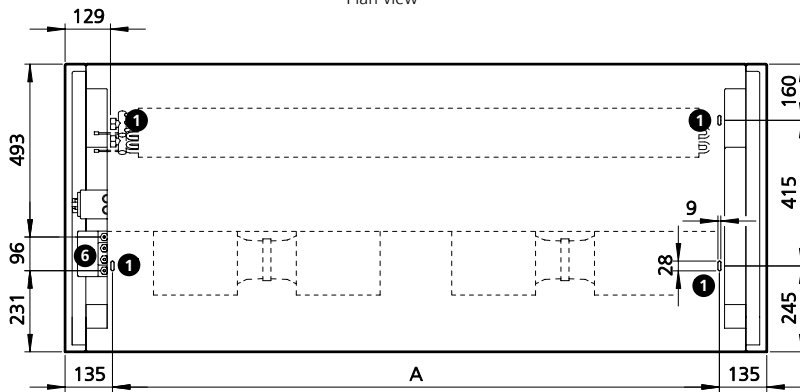

Ceiling brackets, isometric view

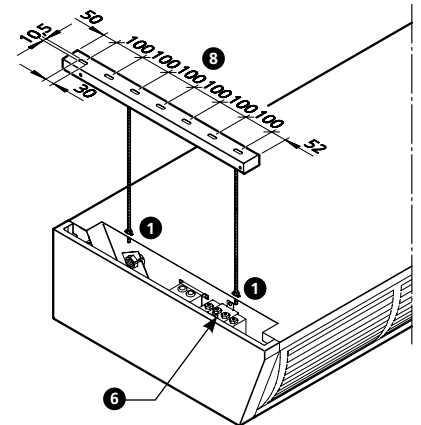

General view

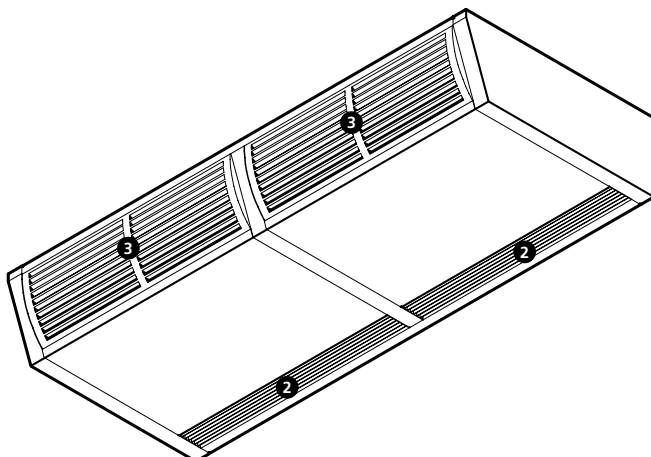

- 1 Fixing points for brackets
- 2 Outlet air rectifier
- 3 Air intake grille with filter insert (optional)
- 4 Flow 3/4"
- 5 Return 3/4"
- 6 Electrical connection area
- 8 Ceiling brackets

5.2.1 Tandem 300 ceiling cassette unit model 12 - 30 with wall brackets

Front view

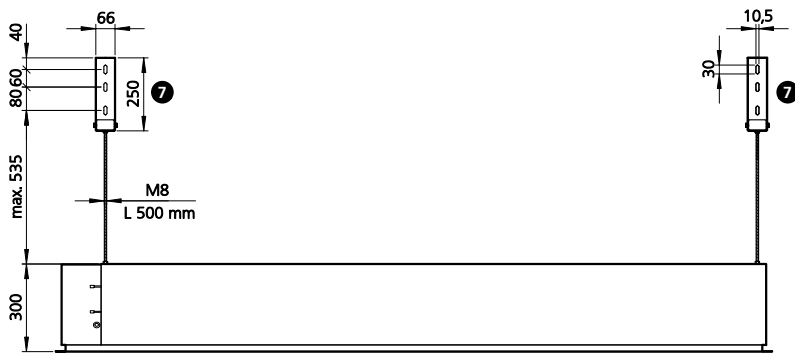

Side view

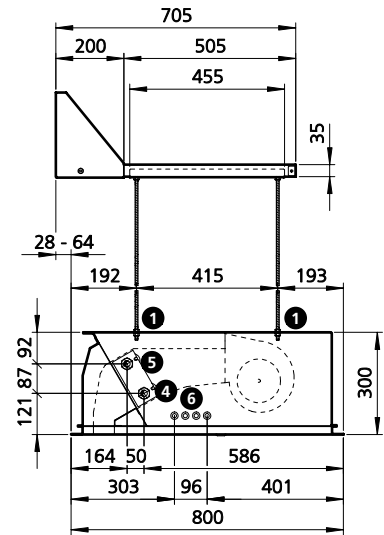

Plan view

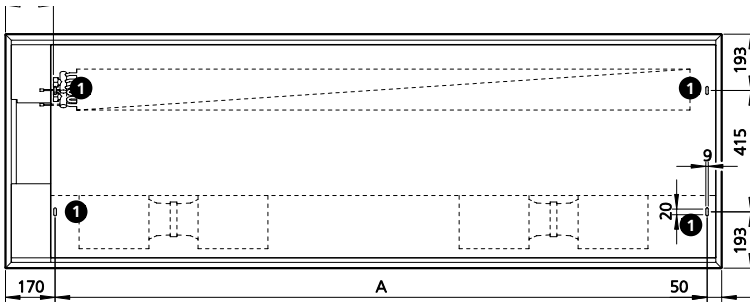

Wall brackets, isometric view

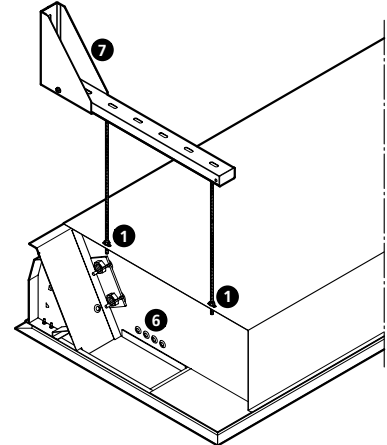

General view

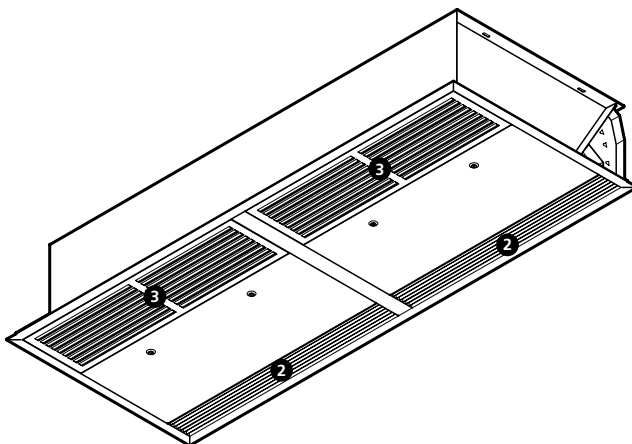

- 1 Fixing points for brackets
- 2 Outlet air rectifier
- 3 Air intake grille with filter insert (optional)
- 4 Flow 3/4"
- 5 Return 3/4"
- 6 Cable opening for electrical wiring
- 7 Wall brackets

5.3 Tandem 300 extension

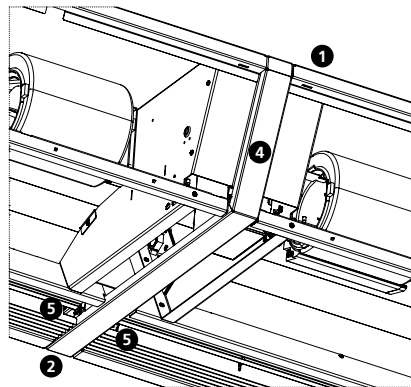
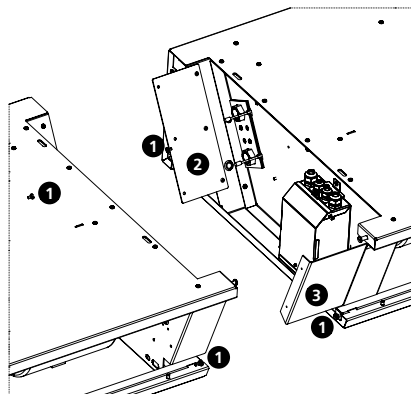
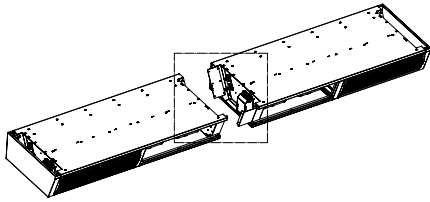

Tandem 300 units can be installed beside each other to create a continuous run using connection set type 3100910. Proceed as follows:

- Dismantle the air intake grille, service hatches and side panels at the connection point
- Remove flat-head screws ① at the connection point
- Fit the connection panel ② (using the screws from the door air curtain)
- Fit the connection panel ③ (using the shoulder screws 4.8 x 9.5 supplied)
- Connect the door air curtains to each other
- Clip in the central support ④ and fix in place with the screws ⑤ provided (pointed screws 3.9 x 9.5 supplied)

6 ▶ Hydraulic connections



Safety information

Connecting up the hydraulics requires expertise in heating engineering. Note the following guidelines for integrating the system before starting work on the unit or on the control:

- Maximum temperature of heating medium 90 °C.
- Maximum operating pressure 10 bar.

Connection to the pipe network

The flow and return connections are located as standard at the side inside the casing on the left side of the unit, as seen from the air intake. The heat exchanger connection is 3/4".

Proceed as follows when making the hydraulic connections:

- Shut off the supply line from the heating medium.
- Connect up the pipework.
- Remove the protective caps from the supply and return pipes.
- Seal the valve connections and connect up, securing the nuts to prevent them from shearing or twisting.

Caution! Use an appropriate tool (e.g. wrench AF 32) to secure the connecting nuts and prevent them from shearing and twisting! Ensure that the connections experience no mechanical tension when fitted!

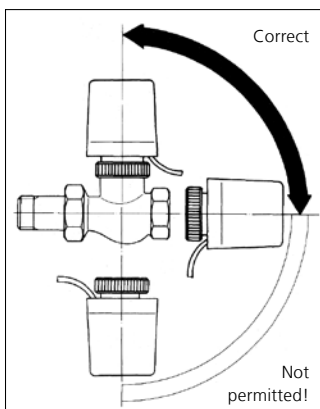

Correct fitting position for 2-point actuator (thermoelectric shut-off valve).



Installation of the valve actuators

Fit a thermoelectric actuator as follows if a thermoelectric shut-off valve is fitted:

- Place the thermoelectric actuator on the valve and tighten the union nut by hand.
- Pull the electrical cable through the openings provided on the unit to the electrical junction box.
- Note the permissible fitting position for the thermoelectric actuator as shown on the illustration on the right.

6.1 Installation of thermoelectric shut-off valve and outlet temperature limit valve



- ❶ Flow 3/4"
- ❷ Return 3/4"
- ❸ Outlet temperature limit valve, type 103968; installation in the flow
- ❹ Thermoelectric shut-off valve, type 100912
- ❺ Opening for remote sensor for outlet temperature limit valve (accessory)
- ❻ Opening for connecting cable for thermoelectric shut-off valve (accessory) and electrical wiring

6.2 Installation of remote sensor for outlet air temperature limit valve



- ❶ Remote sensor for outlet temperature limit valve (accessory), fitting the pipe clips ❷ with screws provided



6.3 Adjusting the air outlet rectifier

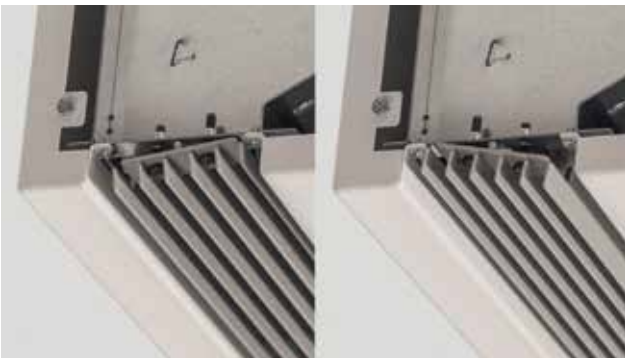

Air outlet adjustment inwards or outwards

The air outlet rectifier has an adjustment range of 20° to tailor the air outlet to individual requirements. The air stream can be specifically and operationally reliably directed outwards or inwards. The air outlet rectifier is factory-set for vertical air outlet.

To adjust the air outlet rectifier, tighten or loosen the screws of the air outlet rectifier, depending on the discharge direction required.

7 ▶ Technical data

Unit		Tandem 300			
Model		12	20	25	30
Length	mm	1250	2000	2500	3000
Weight	kg	64	109	136	158
Current consumption	A	1.91	3.49	4.75	5.11
Max. electrical power consumption	W	262	485	670	741
Mains voltage	V	230	230	230	230
Mains frequency	Hz	50 / 60	50 / 60	50 / 60	50 / 60

Unit		Tandem 300 ceiling cassette unit			
Model		12	20	25	30
Length	mm	1200	1950	2450	2950
Weight	kg	64	103	130	152
Current consumption	A	1.91	3.49	4.75	5.11
Max. electrical power consumption	W	262	485	670	741
Mains voltage	V	230	230	230	230
Mains frequency	Hz	50 / 60	50 / 60	50 / 60	50 / 60

8 ▶ Commissioning

Pre-commissioning checks:

- Is the unit fitted to the wall/ceiling with the appropriate fixing brackets?
- Electrical connection:
 - Is all cabling in accordance with the applicable ambient regulations?
 - Are all wires connected in accordance with the electrical wiring diagrams?
 - Is the earth wire connected and wired throughout?
- Waterside connection:
 - Have the flow and return pipes been laid correctly and fault-free?
 - Are the valves correctly fitted?
 - Are all valves and actuators fitted correctly? (Note the correct mounting position, see chapter 6 from page 15 onwards).

Switching-on

- Switch on the mains voltage.
- Start up the Tandem 300 door air curtain using the control unit connected.
- Check the fan speeds by switching the speed controller.
- Check all further switching and control functions.

Permanent decommissioning

- Switch off the mains voltage.
- **Caution!**
 - In the event of frost:** ■ Shut off the heat exchanger.
 - Drain water out of the heat exchanger!

9 ▶ Maintenance

9.1 Tandem 300



Connection area

The connection area of the Tandem 300 and the type plate are located on the left side of the unit (seen from the air intake). Proceed as follows to open the side panel:

- Pull the side panel ❶ to the front (towards the air intake).
- Place the side panel to the side and keep it safe.
- Close the side panel in reverse order.

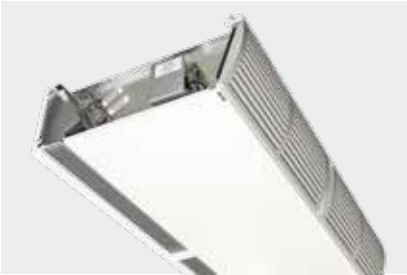

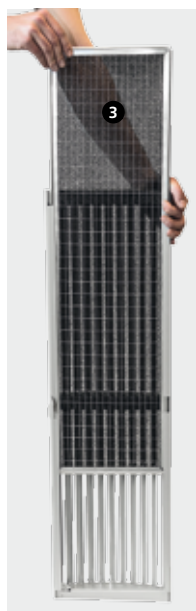

Filter

The heat output of the unit will be reduced with dirty filters and the fans can be damaged by overloading. Regularly check the intake filters.

- Check the intake filters at least 2 x annually and clean if necessary.
- Check and clean the intake filter more regularly depending on the level of dust in the ambient air.
- Open the locking latch on the top corners of the air intake grille **1** with a screwdriver to check and clean the fan and remove the air intake grille from the unit by pressing on the central retaining hook **2**.
- Push the filter frame **3** to the side out of the air intake grille.
- If the filter is dirty, vacuum the filter fabric or wash it out.
- Replace the filter in the event of serious dirt!
- After cleaning/replacement, fit in the reverse order.

Fans and heat exchanger



Caution!

Read the safety information in these instructions in detail before working on fans and heat exchangers!

Adhere to all legally prescribed maintenance intervals. Periodic maintenance depends on the general conditions of operation. Only clean heat exchangers guarantee their full heat output in the long term.



Only open the service hatch once you have removed the air intake grille (as described above). There can be damage to the air intake grille in the event of non-compliance with this.

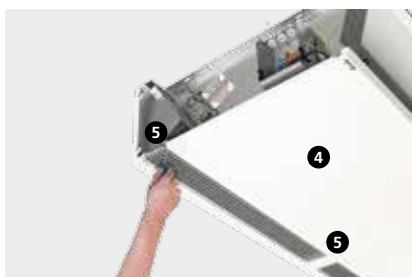

- Maintenance interval: at least every 6 months or more regularly, depending on dirt and dust levels.
- Open the service hatch 4 by loosening the screws 5 in the corners and carefully opening the service hatch downwards.
- Hand the service hatches on the hinges, if required.
- Remove the heat exchanger inspection panel 6 by loosening the screws pointing downwards and carefully removing the panel.
- Carefully clean the heat exchanger with a vacuum cleaner. Avoid damaging the pipes and fins.
- You can perform repair work to the fan and heat exchanger when the service hatch is open. Pay attention to the safety information given in point 2.

9.2 Tandem 300 ceiling cassette unit

Fans and heat exchanger



Caution!

Read the safety information in these instructions in detail before working on fans and heat exchangers!

Adhere to all legally prescribed maintenance intervals. Periodic maintenance depends on the general conditions of operation. Only clean heat exchangers guarantee their full heat output in the long term.

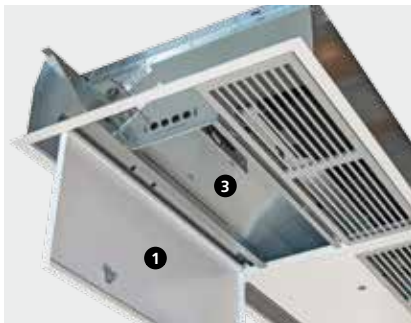

- Maintenance interval: at least every 6 months or more regularly, depending on dirt and dust levels.
- Open the service hatch **1** by opening the lock **2** and carefully open the service hatch downwards.
- Remove the heat exchanger inspection panel **3** by loosening the screws pointing downwards and carefully removing the panel.
- Carefully clean the heat exchanger with a vacuum cleaner. Avoid damaging the pipes and fins.
- You can perform repair work to the fan and heat exchanger when the service hatch is open. Pay attention to the safety information given in point 2.

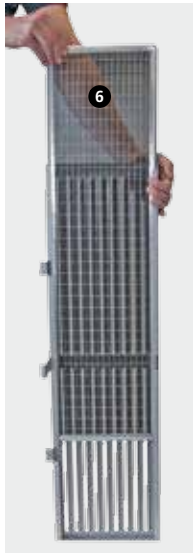

Filter

The heat output of the unit will be reduced with dirty filters and the fans can be damaged by overloading. Regularly check the intake filters.

- Check the intake filters at least 2 x annually and clean if necessary.
- Check and clean the intake filter more regularly depending on the level of dust in the ambient air.
- Open the service hatch ①, as described above, to check and clean the filters, open the air intake grille ④ with a screwdriver and remove the air intake grille from the unit by pressing on the central retaining hook ⑤.
- Push the filter frame ⑥ to the side out of the air intake grille.
- If the filter is dirty, vacuum the filter fabric or wash it out.
- Replace the filter in the event of serious dirt!
- After cleaning/replacement, fit in the reverse order.

10 ▶ Electrical wiring



Safety information

The electrical wiring of this product requires expert knowledge in the field of electrical engineering. This knowledge, generally learned in vocational training in one of the fields stated, is not described separately here.

Only connect up units that have a circuit breaker that switches off all poles from the mains power supply with a minimum contact gap of 3 mm!

The following safety information should be checked and observed before starting any work on the controllers and units:

- De-energise the system and secure against unauthorised switching-on.
- Wire the units as per the wiring diagrams supplied with the units.
- Carry out the electrical connection only in accordance with VDE and EN regulations currently in force as well as the technical wiring regulations (TBAs) issued by the regional electricity providers.
- Only connect the unit to fixed cables.

Errors with the wiring can lead to the unit being damaged! The manufacturer is not liable for any damage to people and materials caused by the wrong wiring and/or improper handling.



Electrical wiring of Tandem 300

The terminal strip is located on the left side of the unit, seen from the air intake, behind the removable side panel.

- Open the side panel, as described in chapter 9.1.
- Remove the terminal cover ❶ (**Caution:** Remove the earth cable).
- Route all electrical cables in line with the unit diagrams supplied. Note the planned control option.

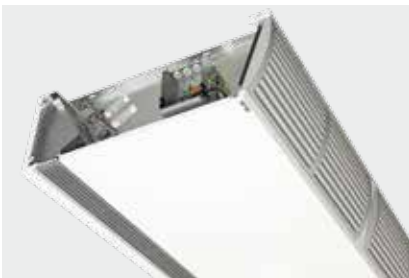

When installing a residual current operated circuit breaker (RCCB), we recommend using a type B RCCB with delayed triggering (super-resistant, characteristic K).

Control options

Cabling and wiring depend on the control accessories used. The relevant wiring diagrams are supplied with the units.



Electrical wiring of Tandem 300 ceiling cassette unit

The terminal strip is located on the left side of the unit, seen from the air intake, behind the pivoting service panel.

- Open the service hatch **1**, as described in chapter 9.2.
- Guide the cable from outside through the cable openings **2** (we recommend passing a 40 cm length of cable into the unit for more convenient wiring).
- Unhook the terminal board **3** by loosening the locking screw **4**.
- Attach the terminal board vertically **5** into the side panel and fix the locking screw **4** in place.
- Remove the terminal box cover **6** (**Caution:** Remove the earth cable).
- Route all electrical cables in line with the unit diagrams supplied. Note the planned control option.
- After wiring, the terminal board **3** is installed in reverse order.

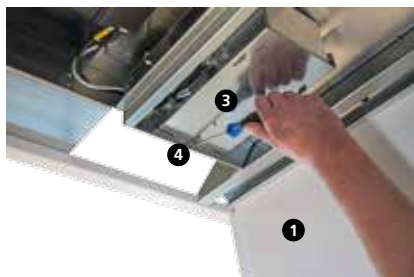

When installing a residual current operated circuit breaker (RCCB), we recommend using a type B RCCB with delayed triggering (super-resistant, characteristic K).

Control options

Cabling and wiring depend on the control accessories used. The relevant wiring diagrams are supplied with the units.

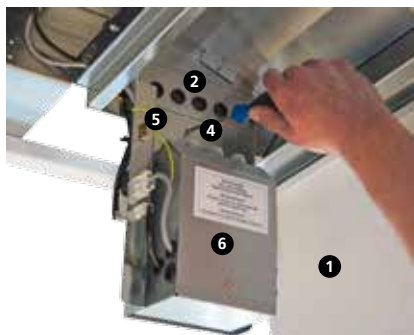

10.1 Electromechanical model with internal fault signal processing (*00)

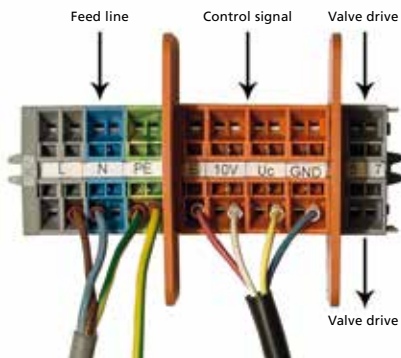

Wiring description:

- The mains voltage is wired to the voltage supply terminals on the door air curtain.
- Continuously variable speed control via an active 0..10 VDC signal.
- Internal evaluation of a possible motor fault and EC fans switched off.
- The heating valve (if fitted) can be opened or closed by the compact controller type 30158 or an on-site switch command.

Compact controller

Combination of operating mode selector switch and speed sensor with options for external control and operation.

The required room temperature is set on the compact controller.

The door air curtain is disabled in standby mode. A frost protection function can be activated by means of settings. In winter mode the fan speed can be set by the knob and the actuator is open. In summer mode the fan speed can be set by the knob and the actuator is closed.

The fan can be allowed to run on or increase the speed by connecting a door contact switch and corresponding parametrisation. Additionally, a room temperature control can be activated, which closes the hot water valve and disables the fan when the set temperature is reached.



Compact control in flat surface-mounted housing, white

Rating IP 30, voltage 230 V / 50 Hz

Dimensions W x H x D: 110 x 110 x 27 mm

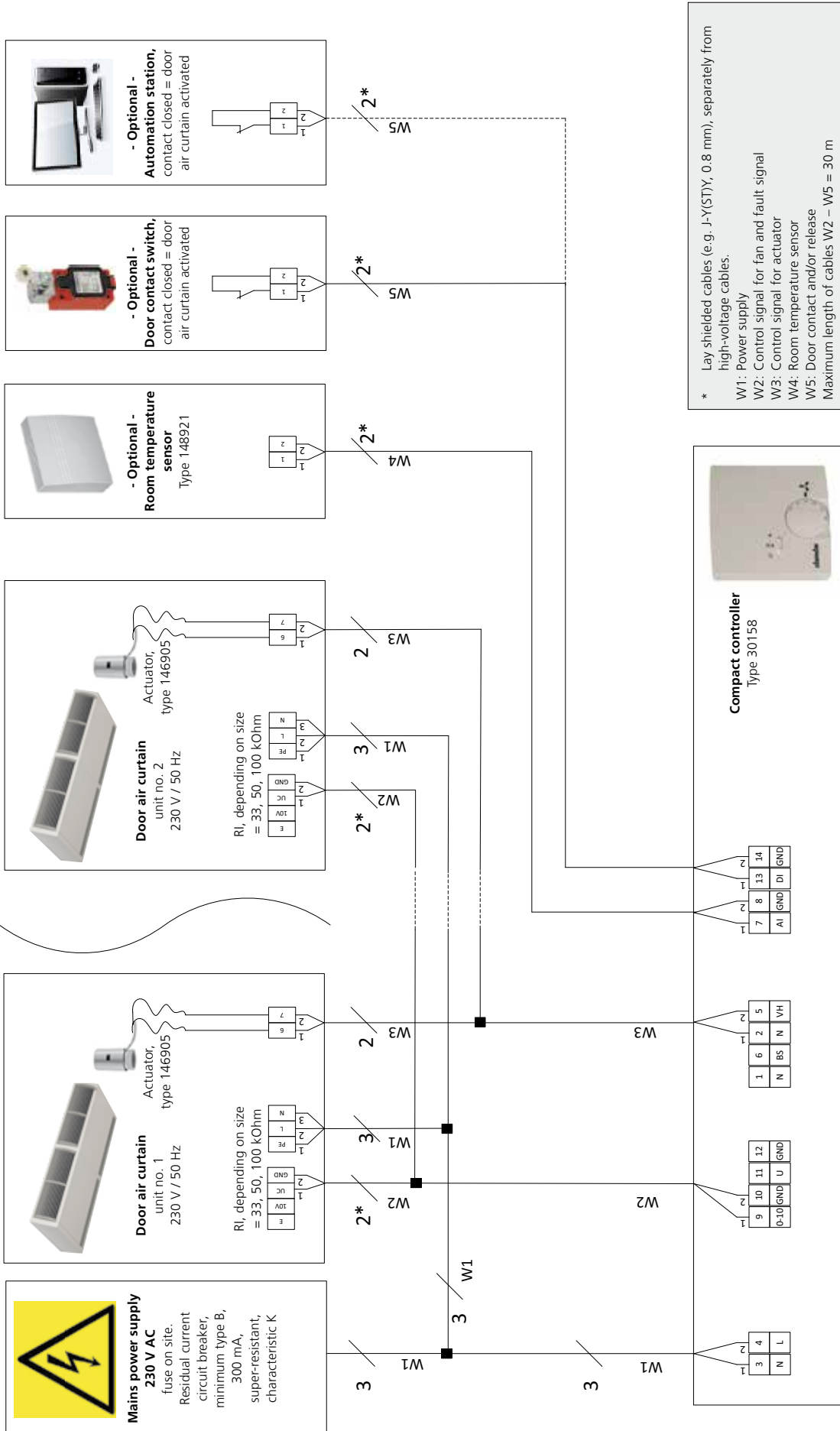

* Lay shielded cables (e.g. J-Y(STY), 0.8 mm), separately from high-voltage cables.
 W1: Power supply
 W2: Control signal for fan and fault signal
 W3: Control signal for actuator
 W4: Room temperature sensor
 W5: Door contact and/or release
 Maximum length of cables W2 – W5 = 30 m

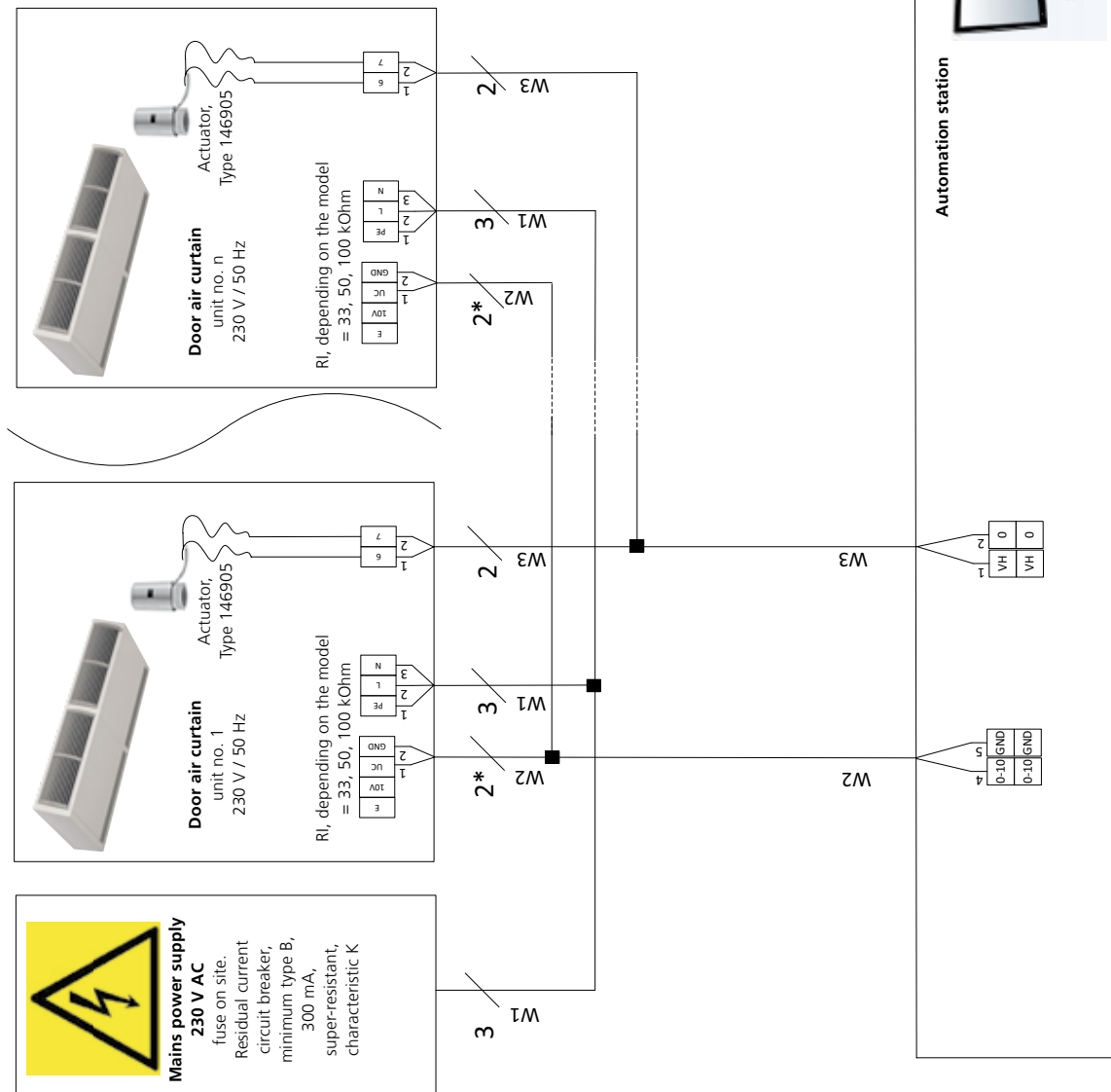

10.2 Electromechanical model with external fault signal processing (*T)



Wiring description:

- The mains voltage is wired to the voltage supply terminals on the door air curtain.
- Continuously variable speed control via an active 0..10 VDC signal or potentiometer.
- Internal evaluation of a possible motor fault and switch off of the EC fans and potential-free fault signal contact.
- Setting option for maximum speed of EC fans via potentiometer.
- The heating valve (if fitted) can be opened or closed by the compact controller type 30158 or an on-site switch command.

Dip switch setting on the PCB:

DIP	Factory setting	Function	Description
1	OFF	Speed signal	OFF: active 0-10 V signal ON: potentiometer 0-100 kΩ
2	ON	Speed signal	OFF: potentiometer 0-100 kΩ ON: active 0-10 V signal

Technical details for inputs/outputs on the PCB

Input impedance 0-10	≥100 kΩ	
Fault signal contact:	U = max. 60 V AC/DC	I = max. 1A
Fuse F1:	1A	
Fuse F2:	4A	

Compact controller

Combination of operating mode selector switch and speed sensor with options for external control and operation.
 The required room temperature is set on the compact controller.
 The door air curtain is disabled in standby mode. A frost protection function can be activated by means of settings. In winter mode the fan speed can be set by the knob and the actuator is open. In summer mode the fan speed can be set by the knob and the actuator is closed.
 The fan can be allowed to run on or increase the speed by connecting a door contact switch and corresponding parametrisation. Additionally, a room temperature control can be activated, which closes the hot water valve and disables the fan when the set temperature is reached.



Compact control in flat surface-mounted housing, white

Rating IP 30, voltage 230 V / 50 Hz

Dimensions W x H x D: 110 x 110 x 27 mm

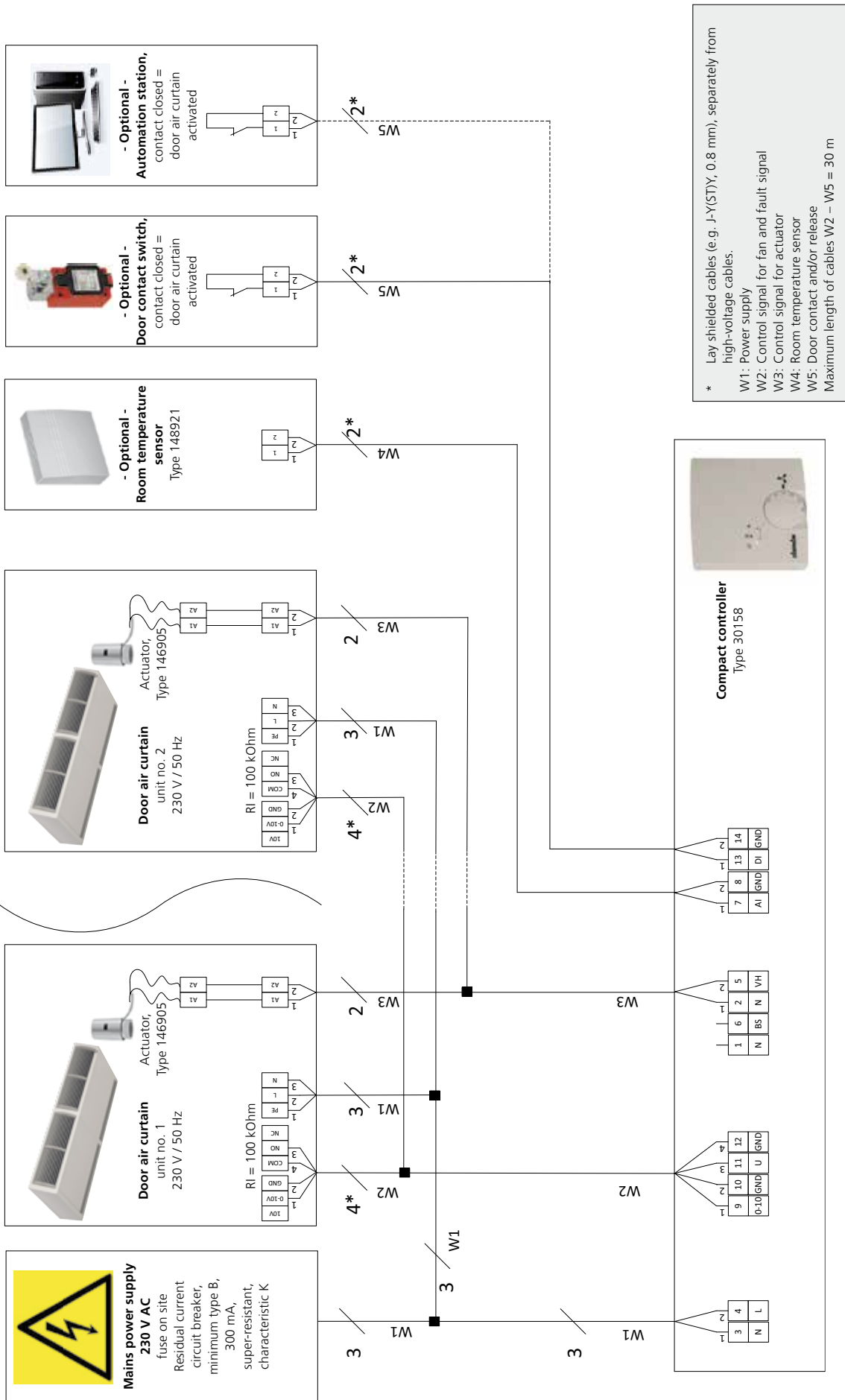

* Lay shielded cables (e.g. J-Y(ST)Y, 0.8mm), separately from high-voltage cables.
 W1: Power supply
 W2: Control signal for fan and fault signal
 W3: Control signal for actuator
 Maximum length of cables W2 = 30 m

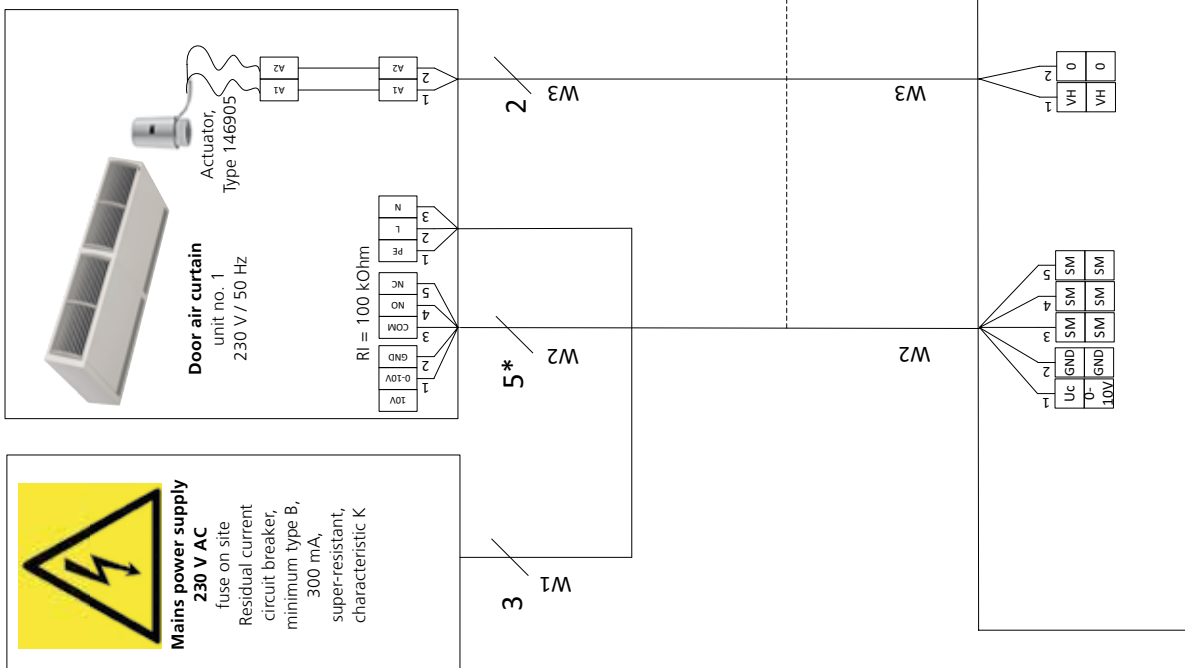

10.3 KaControl model (*C1)

10.3.1 Intended use



Kampmann KaControllers and KaControl modules are built in line with the state of the art and recognised safety regulations. Nevertheless, their use can result in danger to people or damage to the units or other material assets if they are not appropriately installed and operated or correctly and properly used.

Applications

The KaController should only be used as a room unit in conjunction with Kampmann systems.

KaControllers should only be used

- indoors (for instance in residential properties and offices, showrooms etc.)

KaControllers should not be used

- outdoors,
- in humid areas, such as swimming pools, in wet rooms,
- in areas where there is a risk of explosion,
- in areas with a high dust content,
- in areas with an aggressive atmosphere

Protect the products from any moisture during installation. Check the application with the manufacturer in case of any doubt. Any use other than the use specified above is deemed not to be correct and proper.

The operator of the unit is solely responsible for any damage arising as a result of this. Correct and proper use is deemed to include compliance with the installation instructions described in these instructions.

Specialist knowledge

The installation of this product requires specialist knowledge of heating, cooling, ventilation and electrical engineering. This knowledge, generally learned in vocational training in one of the fields mentioned above, is not described separately. Damage caused by improper installation is the responsibility of the operator.

The installer of these units should have adequate knowledge of the following gained from specialist vocational training

- Safety and accident prevention regulations
- Guidelines and recognised technical regulations, i.e. Association of German Electricians (VDE) regulations, DIN and EN standards.

Purpose and scope of these instructions

This manual contains information on the commissioning, functionality and operation of the KaControl system. The information contained in this manual can be altered without prior notification.

10.3.2 Operation of the KaController

The KaController is capable of controlling the wide range of Kampmann products. KaControllers are equipped with state-of-the-art technology and offer users the option of adapting the air conditioning of buildings to individual needs.

Up to two switch-on and switch-off times can be configured for every day of the week so that demand-led temperature control can be set by the user.



Product features:

- integral NTC temperature sensor for room temperature control
- large LCD multifunctional display with clearly arranged icons
- selection of value to be displayed (room temperature, setpoint, offset setpoint)
- automatic LED background lighting
- large seven-segment display for visualisation of the value to be displayed
- real-time clock with integral timer programs
- 2 switching on and 2 switching off times per day
- Eco/day changeover
- Alarm display
- key lock (limited functions for offices, hotels ...)
- manual or automatic mode
- press/Turn button with endless turn/rest function
- one-touch operation of all functions
- connection of Kampmann system components via a BUS connection
- password-protected service level
- language-independent display, ideal for international use

10.3.2.1 Function keys, display elements



KaController with functional keys
Type 3210002
Type 3210004

- 1 Display with LED background lighting
- 2 ON/OFF button (depending on setting)
 - ON / OFF (factory setting)
 - Eco mode/Day mode
- 3 TIMER button
 - set time
 - set timer programs
- 4 ESC button
 - back to standard display
- 5 Navigator dial
 - change settings
 - call up menus
- 6 MODE button
 - set operating modes (disabled with 2-pipe applications)
- 7 FAN button
 - set fan control

All menus can be selected and set using the navigator dial.

The LED background lighting is automatically switched off 5 seconds after the KaController is last used. The LED background lighting can be permanently disabled by means of a parameter setting.



KaController without functional keys
(single-button operation)
Type 3210001
Type 3210003

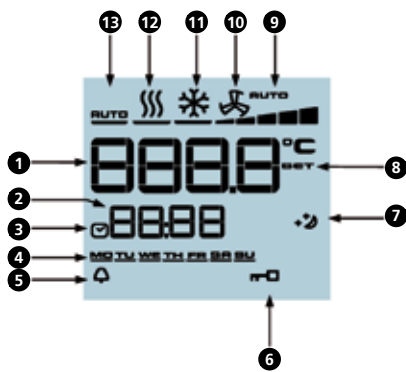

- 1 Display of setpoint room temperature
- 2 Current time
- 3 Timer program enabled
- 4 Weekday
- 5 Alarm
- 6 Selected function is locked
- 7 Eco mode
- 8 Setpoint setting enabled
- 9 Fan control setting Auto-0-1-2-3-4-5
- 10 Ventilation mode
- 11 Summer mode
- 12 Heating mode
- 13 Automatic heating/cooling changeover mode

The symbols shown on the display depend on the application (2-pipe, 4-pipe etc.) and the parameters set.

10.3.2.2 Operation

The KaController is operated by the navigator and the function keys.

The functions that can be called up and set using the navigator are identical on both versions (with and without function keys on the side). An illustration of the KaController with the function keys at the side is used throughout these instructions for ease of understanding.

The navigator dial or side function keys are also used to select the various selection menus.

Menu selection using the navigator dial

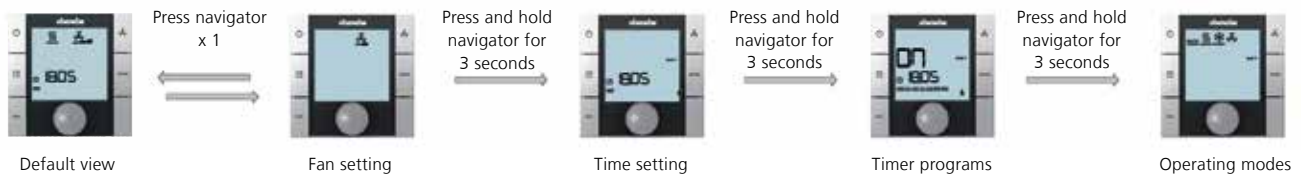

Menu selection using function keys

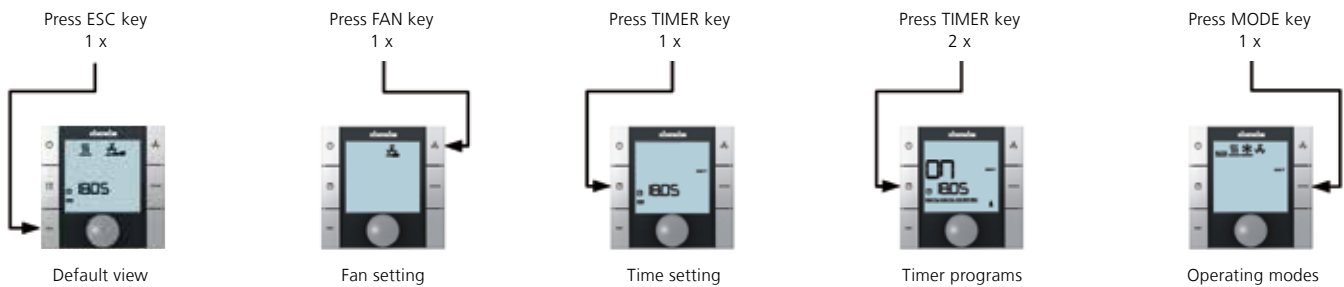

i If no action is carried out using the navigator dial or the functional keys for longer than 3 seconds, the last change made is saved and the standard view is called up.



Switching control off and on

When the control is switched on, the display shows the default view with the current room temperature setpoint and the fan stage set.



Following initial commissioning of the KaController, the time is no longer shown in the default view (see "Time setting" selection menu).



Switching off the control:

There are 3 options for switching off the control:

1. Press the ON/OFF button.
2. Turn the navigator dial to the left until OFF appears.
3. Press and hold down the navigator dial until OFF appears.



Switching on the control:

There are 2 options for switching on the control:

1. Press the ON/OFF button.
2. Press the navigator dial.

Fan setting

Press the FAN key (quick access) or use the navigator dial to call up the “Fan setting” selection menu.

Calling up the “Fan setting” menu using the navigator dial:

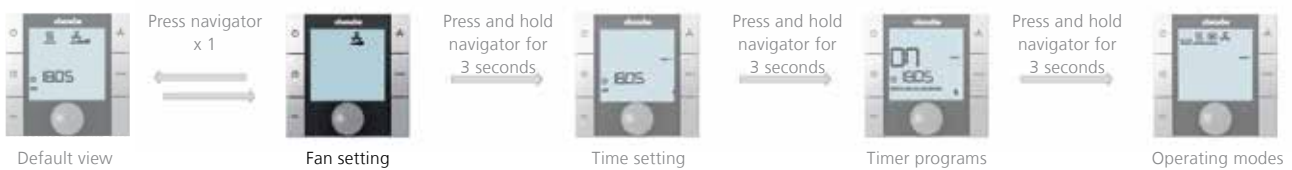

Fan stage 3

The room temperature is initially controlled with natural convection in automatic mode and then by continually adjusting the fan speed. Users also have the option of setting fan stages Auto-0-1-2-3-4-5 as required.

Pressing the navigator dial in the default view switches the display to the “Fan setting” menu.

You can select the required fan stage Auto-0-1-2-3-4-5- by turning the navigator.

Pressing the navigator dial activates the selected fan stage.

i If no action is carried out using the navigator dial or the functional keys for longer than 3 seconds, the last change made is saved and the standard view is called up.

Summer mode/winter mode adjustment

Press the MODE key (quick access) or use the navigator dial to call up the “Operating modes” selection menu.

Calling up the “Operating modes” menu using the navigator dial:

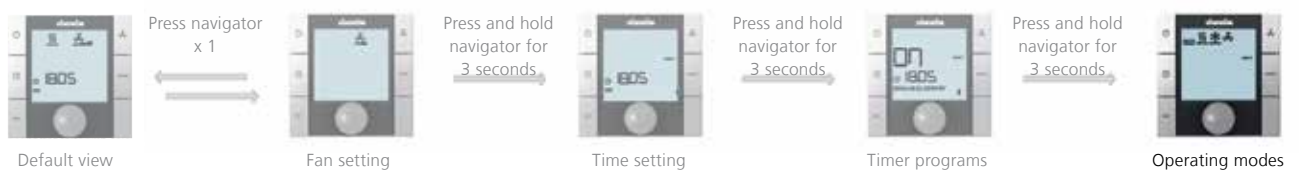

You can use the navigator dial to set the operating mode depending on the parameter setting.

Operating mode - summer mode: the controller operates only in summer mode (Fan ON, Heating OFF).

Operating mode - winter mode: The controller operates only in cooling mode (Fan ON, Heating ON).

The operating mode required can be selected by turning the navigator dial in the ‘Operating mode’ selection menu.

Pressing the navigator dial activates the selected operating mode.



Setting winter mode

i If the summer mode / winter mode changeover is actuated by an external thermostat, the KaController cannot perform the summer mode / winter mode changeover.

i If no action is carried out using the navigator dial for longer than 3 seconds, the last change made is saved and the standard view is called up.

Time setting

Press the TIMER key (quick access) or use the navigator dial to call up the “Time setting” selection menu.

Calling up the “Time setting” menu using the navigator dial:

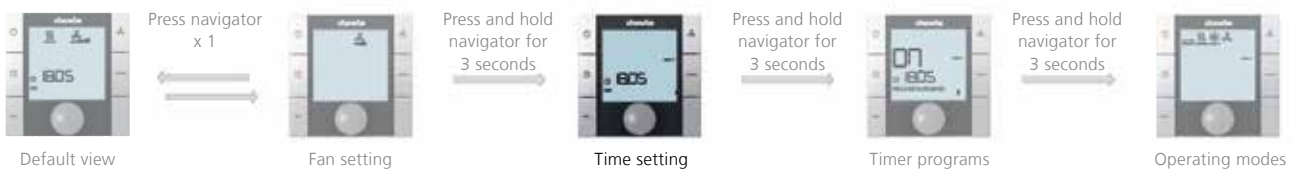

Time setting view

Setting the time

Use the navigator dial to set the following:

1. Current hour
2. Current minute
3. Current day

i The “Timer programs” selection menu is automatically called up once the current day has been confirmed by pressing the navigator dial.

i If no action is carried out using the navigator dial for longer than 7 seconds, the last change made is saved and the default view is called up again.



Setting to hide the time in the default view

i Following initial commissioning of the KaController, the time is no longer shown in the default view. Only when the time has been set, is the current time shown in the default view. If “- -: --” is entered for hours and minutes, the real-time clock is disabled and the time is hidden in the default view.

Time switch programs

The KaController provides the option of programming switching on and off times using a timer program if rooms are only to be air conditioned during certain times of the day. Unlike with conventional thermostatic controllers where only one switching on and off time can be selected, two switching on and off times can be set for each day.

Timer matrix

	ON1	OFF1	ON2	OFF2
MO	6 : 00	18 : 00	--- : ---	--- : ---
TU	6 : 00	18 : 00	--- : ---	--- : ---
WE	6 : 00	18 : 00	--- : ---	--- : ---
TH	6 : 00	18 : 00	--- : ---	--- : ---
FR	6 : 00	18 : 00	--- : ---	--- : ---
SA	8 : 00	14 : 00	--- : ---	--- : ---
SU	--- : ---	--- : ---	--- : ---	--- : ---

Example of a weekly timer program



Set the time in the "Time setting" selection menu before parametrising the switch-on and off times.

The KaController can manage 2 switch-on and 2 switch-off times per day. The switching on and off times can be entered as a block or individually for each day.



The timer program switches the controller on and off in accordance with the timer entries. After switching off the controller using the timer program, the user then has the option of switching the controller on using the ON/OFF key or the navigator dial.



If no switch-on or off time is entered in the timer program matrix, the "Clock" symbol is hidden in the default view.



Display elements in the timer program selection menu

- 1 ON = SWITCH ON timer program
OFF = SWITCH OFF timer program
- 2 1 = Timer program no. 1
2 = Timer program no. 2
- 3 Switching on/switching off time
- 4 Weekday
- 5 If no switch-on or off time is entered in the timer program matrix, the "Clock" symbol is hidden in the default view.

The diagram below shows the sequence for setting the timer program. Steps 1-4 are described in more detail in the next section.

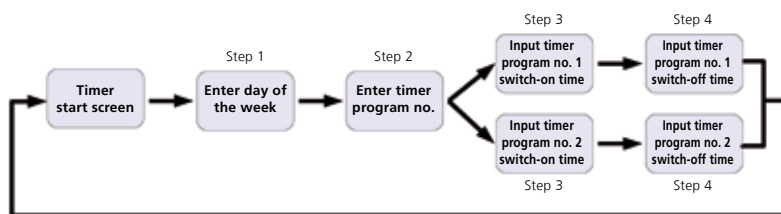

To exit the "Timer programs" selection menu, press and hold down the navigator dial for 3 seconds in the timer program start screen or do not use the KaController for 15 seconds.

Press the TIMER key twice (quick access) or use the navigator dial to call up the “Timer programs” selection menu.

Use the navigator dial to call up the “Timer programs” menu.

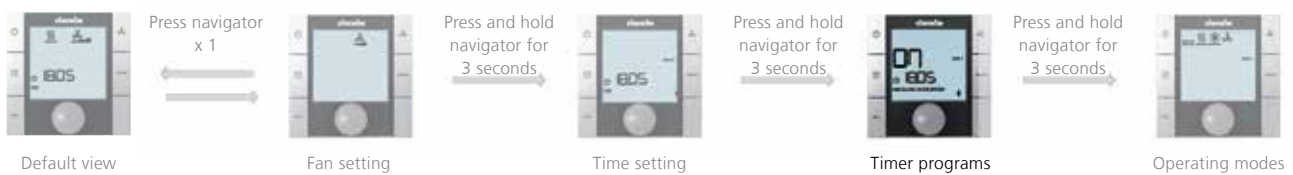

Timer start screen

Step 1:

Turn the navigator to select a weekday for which you would like to program a switch-on or off time.

You have the option of selecting the days of the week as a block (MO-FR, SA-SU, MO-SU) or individually.

Press the navigator dial to apply the figure (for instance: MO-FR) and to call up the next input screen.



Enter timer program no.

Step 2:

Turn the navigator dial to select the number of the timer program (no. 1 or no. 2).

Press the navigator dial to apply the figure (for instance: Timer program no. 1) and to call up the next input screen.



Input screen for **switching on time**

Step 3:

Set the **switch-on time** you require by turning the navigator dial.

Once the minutes have been set, the set **switch-on time** is carried over by pressing the navigator dial and the input screen for the switch-off time of the selected program no. is called up.

Input screen for **switch-off time****Step 4:**

Set the **switch-off time** you require by turning the navigator dial. Once the minutes have been set, press the navigator dial (⇒ Step 1) to apply the **switch-off time** and call up the timer start screen.

IMPORTANT NOTE!

- Call up the respective weekday and associated timer program no. to delete switching-on and switching-off times entered (Step 1 + Step 2). Replace the switch-on or off time entered by "--:--; --" (Step 3 + Step 4).
- You can overwrite timer entries at any time either as a block or for each day.
- Only request switch-on and off times singly for each day. It is not possible to request switching-on and off times as a block where there are differing time entries for the respective days of the week and the time is then shown by "--:--".
- To exit the "Timer programs" selection menu, press and hold down the navigator dial for 3 seconds in the timer program start screen or do not use the KaController for 15 seconds.



Deleting all timer programs and time

Perform the following steps to delete all timer programs and the time:

1. Switch off the KaController by:
 - Pressing the ON/OFF key
 - Press the navigator for a minimum of 5 seconds
 - Turn the navigator to the left until OFF appears
2. Press the navigator dial for a minimum of 10 seconds to call up the Service menu. The display shows "Para" and then "CODE" with the value 000 in sequence.
3. Select code 44 by turning the navigator dial and confirm by pressing the navigator dial. Now all timer programs and the time are deleted.
4. There are 3 options to exit the Service menu and call up the Standard view:
 - If no action has been carried out using the navigator dial for longer than 2 minutes.
 - Hold down the navigator dial for 5 seconds.
 - Turn the navigator dial to select "ESC" on the display and confirm the selection by pressing the navigator dial.
5. Disconnect the unit for approx. 1 minute to apply the change.

10.4 Alarm messages

The KaController displays faults by means of the alarm messages listed in the table below. The alarm messages are displayed according to their priority.

In the event of an alarm, note down the alarm message and contact the responsible member of staff (System Administrator or Installer/Service Technician) to fix the fault quickly.



View of "Condensation alarm"
(Alarm A14 shown)

SmartBoard alarm table

Code	Alarm	Priority
A11	Faulty control sensor	1
A12	Motor fault (local stop)	2
A13	Room frost protection	3
A14	Condensation alarm	4
A15	General alarm	5
A16	Faulty AI1, AI2 or AI3 sensor	6
A17	Unit frost protection	7
A18	Faulty EEPROM	8
A19	Offline slave in the CAN-BUS-network	9



KaController alarm table

Code	Alarm
Code	Alarm
tAL1	Temperature sensor in KaController faulty
tAL3	Real-time clock in KaController faulty
tAL4	EEPROM in KaController faulty
Cn	Communication fault with the external control

Should more than one fault occur simultaneously in the KaController control electronics, the alarm messages are displayed alternately in the display.

10.5 KaController installation

Installation/Dismantling

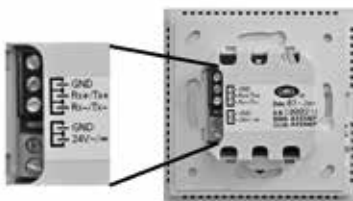
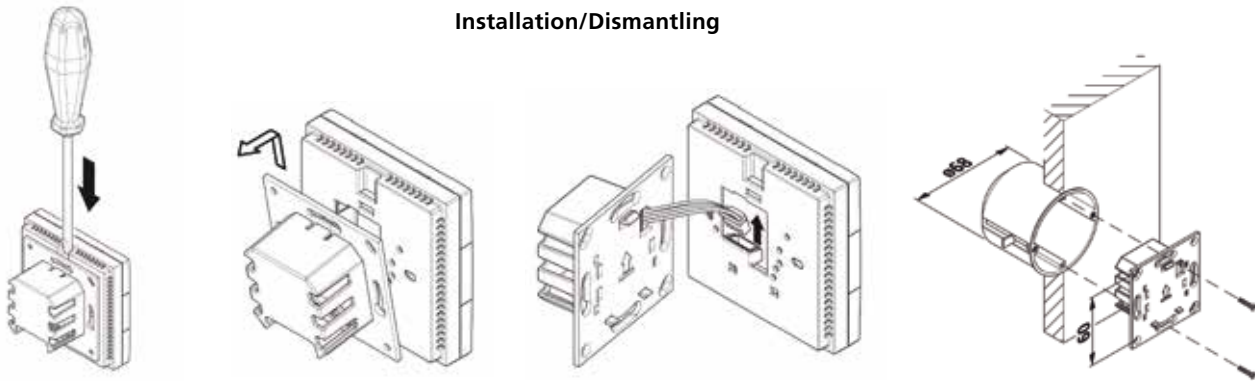

KaController terminals

Electrical wiring

- Connect the KaController to the nearest KaControl in accordance with the wiring diagram. The maximum BUS length between the KaController and the KaControl is 30 m.
- Connecting a KaController to it automatically converts the respective KaControl to the master unit in the control circuit.



Disconnect the unit prior to embarking on “all” wiring work!



Only connect the BUS lines to the KaControl when the unit is fully disconnected.

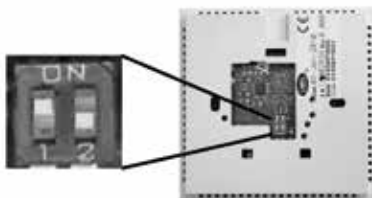

DIP switch setting
KaController
DIP switch no. 1: **ON**
DIP switch no. 2: **OFF**

DIP switch setting

- The DIP switches on the rear of the KaController should be set according to the illustration at the side:
DIP switch no. 1: **ON**
DIP switch no. 2: **OFF**

10.5.1 Troubleshooting A11 – A17

The fault messages of a slave unit are not displayed on the KaController. Only the fault messages of the master unit are displayed on the KaController.

A11 Control sensor faulty

The room temperature is regulated on the selected control sensor, that is to say, depending on the DIP switch setting, the external room sensor/intake sensor can be faulty, depending on the DIP switch setting. If the room sensor in the KaController is faulty, this display alternates with tAL1.

Effect of this alarm:

The fan is switched off and the valves close.

A12 Motor protection control sensor

Any motor fault with a KaControl is shown on the KaController by the display "A12".

When a motor fault has occurred, check whether the fan is blocked.

To rectify the fault, disconnect the unit and eliminate the source of the fault.

Ultimately, the unit should start up again after the voltage has been switched on and a fan stage switched on.

Effect of this alarm:

The fan is switched off and the valves close.

A13 Room frost protection function

The room temperature is monitored in this state to a limit of 8 °C. The room frost protection function is activated if the room temperature drops below 8 °C. The room frost protection function is disabled if the room temperature rises above the limit value of 8 °C.



The limit of 8 °C is fixed for the room frost protection function and cannot be changed.

Effect of this alarm:

The heating valve opens and fan stage 1 is switched on.

A14 Condensation alarm

The condensation alarm of a unit with KaControl is displayed on the KaController by the display "A14". The unit with an active condensation alarm automatically closes all valves.

Check that the condensation pump is running correctly and check the water level in the condensation tank if a condensation alarm occurs.

Effect of this alarm:

The heating valve opens and fan stage 1 is switched on.

A15 General alarm

The general alarm with units with KaControl is only triggered if the inputs on the KaControl have been correspondingly parametrised.

Effect of this alarm:

The heating valve opens and fan is switched on.

A16 Faulty AI1, AI2 or AI3 sensor

The sensor alarm is displayed if one of the active sensors does not transmit viable measured values to the KaControl.

Check the correct wiring of the KaControl and check the sensor.

Effect of this alarm:

The heating valve opens and fan is switched on.

A17 Unit frost protection function

The temperature at the temperature sensor is monitored at each phase in the system to a limit of 4 °C. The unit frost protection function is activated if the temperature drops below 4 °C. The heating valve opens and fan is switched on.

The unit frost protection function is disabled when the temperature at the sensor rises above the limit of 4 °C. The unit frost protection function is also activated if the room temperature drops below 4 °C.



The limit of 4 °C is fixed for the unit frost protection function and cannot be changed.

Effect of this alarm:

The heating valve opens and fan is switched on.

10.6 Cabling

10.6.1 General information

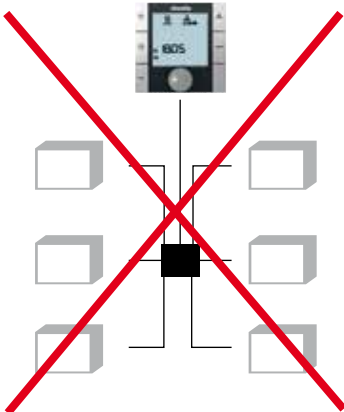

Wrong!
Star-shaped wiring of the BUS lines

- Route all low voltage cables along the shortest route.
- Ensure that low-voltage and high-voltage cables are separated, using metal partitions in cable ducts.
- Use only shielded cables as low-voltage and BUS cables.
- Lay all BUS cables in a linear pattern. Star-shaped wiring is not permitted (Figure on left).
- The KaController is connected via a BUS connection to the respective control PCB on the unit.



Use shielded, paired cables as BUS cables, for instance CAT5 (AWG 18), but at least of the same value.



When laying BUS cables, avoid the formation of star points, for instance in junction boxes. Pass the cables through to the units!

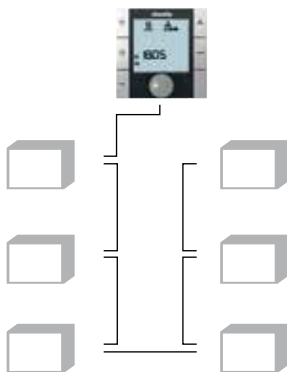

Right!
Linear wiring of the BUS lines

10.6.2 KaController

Flush-mounted back box



** Lay shielded, paired cables, e.g. CAT5 (AWG23) of at least the same value, separately from high-voltage cables.

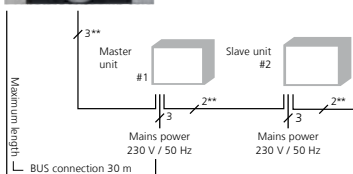

- A flush-mounted back box is required for the KaController.
- Connect the KaController to the nearest KaControl as per the wiring diagram. The maximum BUS length between the KaController and the KaControl unit is 30 m.
- Connecting a KaController to it automatically converts the respective KaControl to the master unit in the control circuit.

10.6.3 External room temperature sensor

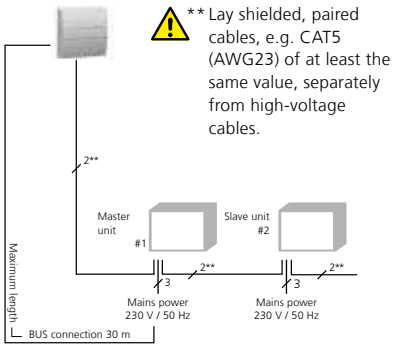

- All KaControl master units have an analogue input to connect an external room temperature sensor.
- Connect up the cables in accordance with the wiring diagram and use the DIP switch and KaController to configure the functions.
- The maximum cable length between the master unit and the room temperature sensor is 30 m.



It is not possible to connect an external room temperature sensor to the slave units.
Set the DIP switch no. 6 to OFF when using an external room temperature sensor on a master unit.

10.6.4 Inputs for processing external contacts (e.g. on-site BMS etc.)

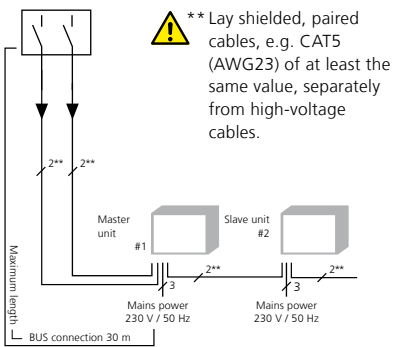

- All KaControl master units have multifunctional inputs that can be assigned different functions during commissioning.
- Connect up the cables in accordance with the wiring diagram and use the KaController to configure the functions.
- The maximum cable length between the master unit and the external potential-free contacts is 30 m.



No external contacts (e.g. window contact, card reader etc.) can be connected to the slave units.

10.6.5 Internal unit temperature

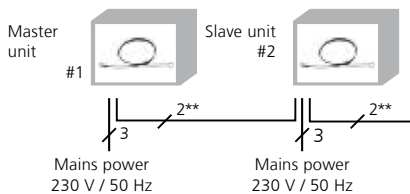

- All KaControl units have multifunctional inputs that can be assigned different functions during commissioning, e.g. an internal temperature sensor in the unit for frost protection monitoring.
- Connect up the cables according to the wiring diagram and use the KaController to configure the functions.



Set the DIP switch no. 3 to ON when using an internal temperature sensor in the unit.

10.7 Addressing – Single-circuit controls

- KaControl units in single-circuit controls with a maximum of 6 units need not be addressed.
- Define the master unit/slave unit by connecting the KaController.
- The respective KaControl automatically becomes the master unit in the control circuit when a KaController is connected to it.
- A master unit must not necessarily be arranged at the end of a BUS system.
- Lay all BUS cables in a linear pattern. Star-shaped wiring is not permitted.

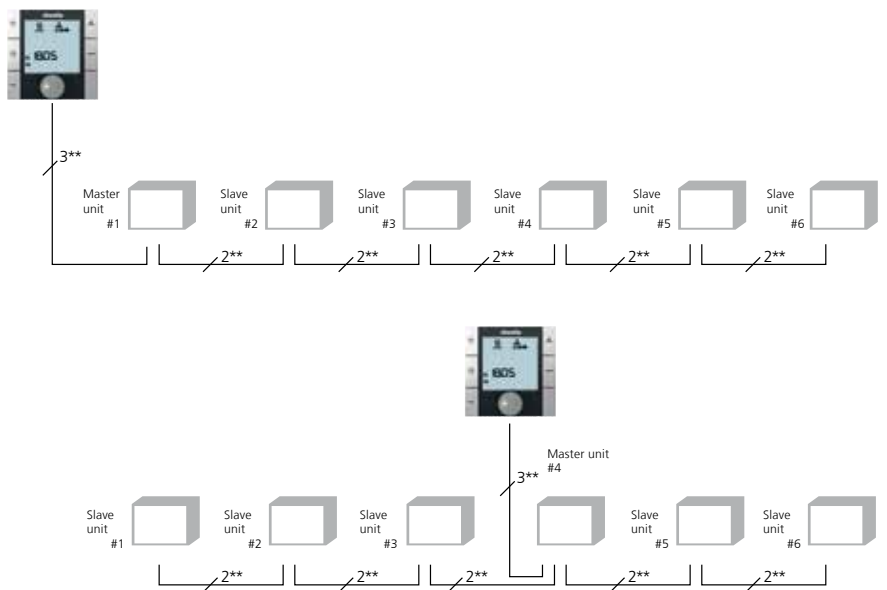

10.8 Setting the unit configuration by means of DIP switches

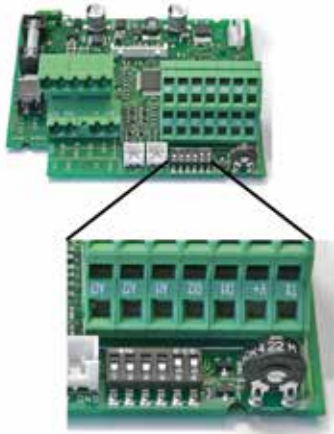

Set the configuration of a KaControl unit using the DIP switch on the PCB. Once the DIP switch has been set, all the basic functions of the configuration have been parametrised and the KaControl can be operated immediately.

Special setting options, such as lowering the temperature setpoint during Eco mode, have to be parametrised in the Service menu. This parametrisation is possible using the KaController.

Open the control unit to check and possibly adjust the DIP switches.

The DIP switches are factory-set in accordance with the unit configuration!



Disconnect the control before starting to adjust the DIP switches.

Functional table of DIP switch settings on the PCB

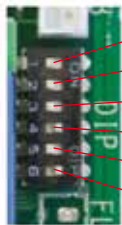

DIP1	OFF = --- ON = 0...10 V actuation by means of an on-site measurement and control system
DIP2	OFF = --- ON = Actuation by potentiometer 0...100 kOhm
DIP3	OFF = No clip-on sensor fitted ON = Clip-on sensor fitted
DIP4	OFF = 4-pipe if winter/summer changeover via clip-on sensor ON = Winter/Summer changeover via DI2
DIP5	OFF = 2-pipe system ON = 4-pipe system
DIP6	OFF = Room control on intake air/ext. room sensor ON = Room control to sensor in the KaController



With slave units, DIP switch no. 6 must be set to ON if the room temperature is detected via an external room sensor or the KaController.

10.9 Parameter settings

Special system requirements can be configured using parameter settings in the Service menu.

Special system requirements may include:

- Display: room temperature or setpoint temperature
- Locking operating functions
- Setting absolute setpoint temperature or $\pm 3K$
- Setting parameters in Eco / Day mode
- Sensor calibration

The required settings can be made using the KaController.

Service menu

The following steps are needed to set the parameters:

1. Switch off the KaControl unit by:
 - Pressing the ON/OFF key
 - or
 - Press the navigator for a minimum of 5 seconds
 - or
 - Turn the navigator to the left until OFF appears
2. Press the navigator dial for a minimum of 10 seconds to call up the Service menu. The display shows "Para" and then "CODE" with the value 000 in sequence.
3. Select the password (code) 22 by turning the navigator dial and confirm by pressing the navigator dial. You are now in Service level 1 and the display shows the current software version (P000=...).
4. Parameters can now be set using the navigator.
5. Setting parameters:
 - Turn the navigator dial to select the parameter.
 - Press the navigator dial to call up Edit mode.
 - Set the required value by turning the navigator dial.
 - Press the navigator dial to save the new value.
6. There are 3 options for exiting the Service menu and calling up the standard view:
 - If no action has been carried out using the navigator dial for longer than 2 minutes.
 - Hold down the navigator dial for 5 seconds.
 - Turn the navigator dial, select "ESC" on the display and confirm the selection by pressing the navigator dial.



Parameter changes within the Service menu are only transmitted in the master unit.

Connect a KaController to the respective slave unit to change the parameters on slave units.

10.10. Parameter settings

10.10.1 Setting absolute setpoint temperature or $\pm 3K$



Parameter P36=0
Setting of "absolute" setpoint temperature

Parameter P36

It may be necessary in office or hotel applications for the system operator to specify a base setpoint. The user has the option of changing the setpoint temperature by $\pm 3K$ to even out any different perception of room temperature.

Alternatively the setpoint can be set in absolute values.

Parameter P36 is used to configure the setpoint setting.

	Function
P36	Setpoint setting 0 = Absolute setpoint setting 1 = Setpoint setting $\pm 3K$

Use parameter P01 to configure the base setpoint for the "Setpoint setting $\pm 3K$ ".

	Function
P01	Base setpoint for setpoint entry $\pm 3K$



Parameter P36=1
Setting of setpoint temperature $\pm 3K$



When the parameters are being set
 P37=1 \Rightarrow Display setpoint temperature
 P36=1 \Rightarrow Setpoint setting $\pm 3K$
 no setpoint is shown in the standard display!

10.10.2 ON/OFF, Eco/Day functions

Parameter P38

The function of the ON/OFF key and the timer programs are specified by parameter P38.

Use the ON/OFF button and the timer programs to switch the unit ON and OFF or between Eco and Day mode.

Option 1:

The ON/OFF key and timer programs are used to switch between Eco mode and Day mode.

Option 2:

Use the ON/OFF key and the timer programs to switch the KaControl on and off.

Parameter P38 can also be set for the “Winter/summer changeover using clip-on sensor” function (Section 10.3.7).

	Function
P38	8 = Eco/Day mode changeover 26 = Eco/Day mode changeover + Winter/summer changeover via clip-on sensor (2-pipe system) 72 = ON/OFF changeover 90 = ON/OFF changeover + Winter/summer changeover via clip-on sensor (2-pipe system)



Alternatively the KaControl unit can be switched on and off via an external potential-free contact or between Eco mode and Day mode. The configuration is described in Section 10.3.14.

10.10.3 Function of DI2

The digital input DI1 is predominantly used to execute specific functions. If the use of the digital input DI2 is needed, then the following settings have to be made:

1. Set DIP switch no. 4 to OFF.
2. Configuration of the digital input DI2 using parameter settings P44.



If DIP switch no. 4 is set to ON, digital input DI2 changes over from winter to summer in a 2-pipe system.

Parameter P44

Parameter P44 is used to set the function of the digital input DI2 when DIP switch no. 4 = OFF.

	Function	Standard	Min.	Max.	Unit
P44	Function of DI2 0 = No function 1 = ON/OFF (contact open ⇨ ON) 2 = Winter/Summer changeover (contact open ⇨ heating) 3 = Eco/Day mode (contact open ⇨ Day) 4 = No function (contact open ⇨ without function) 5 = Condensation alarm (contact open ⇨ no condensation) 6 = General alarm (contact open ⇨ no alarm) 7 = External frost protection monitor (contact open ⇨ no frost) 8 = ON/OFF (contact closed ⇨ ON) 9 = Winter/Summer changeover (contact closed ⇨ heating) 10 = Eco/Day mode (contact closed ⇨ Day) 11 = No function (contact closed ⇨ no function) 12 = Condensation alarm (contact closed ⇨ no condensation) 13 = General alarm (contact closed ⇨ no alarm) 14 = External frost protection monitor (contact closed ⇨ no frost)	0	0	14	

Parameter P56

The polarity of digital input DI2 is set using parameter P56 when setting DIP switch no. 4 to ON.

	Function	Standard	Min.	Max.	Unit
P56	polarity of DI2, if DIP 4 = ON (Switch winter/summer by DI2) 0 = contact closed ⇨ winter contact open ⇨ summer 1 = contact open ⇨ winter contact closed ⇨ summer	1	0	2	

10.10.4 Function of digital outputs V1 and V2

The function of the digital output V1 is permanently assigned.

The function of the digital output V2 can be configured using parameters.

Digital output V2

The digital output V2 is used to control the heating valve in a 4-pipe system.

The digital output V2 can be configured using parameter P39.

	Function	Standard	Min.	Max.	Unit
P39	Function V2 in a 2-pipe system 0 = No function 1 = Heat requirement 2 = Cooling requirement 3 = Unit alarm	0	0	3	



24 V DC is connected to digital output V2. The digital output is not a potential-free contact and can only be used with appropriate wiring!

10.10.5 Function of multifunctional inputs AI1, AI2 and AI3

The function of the multifunctional inputs AI1, AI2 and AI3 can be configured using parameter settings.

Function AI1 – Parameter P15

Parameter P15 is used to set the function of the multifunctional input AI1.



The multifunctional input AI1 can only be set using parameter P15 if DIP switch no. 6 is set to ON! The setting of DIP switches is described in section 10.

	Function	Standard	Min.	Max.	Unit
P15	Function of AI1 0 = Not used (input disabled) 1 = NTC outside air sensor 2 = NTC cold/hot water sensor (clip-on sensor) 3 = NTC cold water sensor (clip-on sensor) 4 = NTC hot water sensor 5 = NTC external room temperature sensor / induction sensor 6 = 0..100 K ohm fan actuation 7 = 0..100 K ohm temperature setpoint 8 = 0..100V BMS winter/summer control 9 = 0..100V BMS winter control 10 = Eco/Day mode contact open ⇨ day 11 = No function contact open ⇨ without function 12 = Condensation alarm contact open ⇨ no condensation 13 = General alarm contact open ⇨ no alarm 14 = External frost protection monitor contact open ⇨ no frost 15 = Eco/Day mode contact open ⇨ day 16 = No function contact closed ⇨ no function 17 = Condensation alarm contact closed ⇨ no condensation 18 = General alarm contact closed ⇨ no alarm 19 = External frost protection monitor contact closed ⇨ no frost	0	0	19	

Function AI2 – Parameter P16

Parameter P16 is used to set the function of the multifunctional input AI2.

 The multifunctional input AI2 can only be set using parameter P16 if DIP switch no. 3 is set to OFF! The setting of DIP switches is described in section 10.

	Function	Standard	Min.	Max.	Unit
P16	Function AI2: see P15	0	0	19	

Function AI3 – Parameter P17

Parameter P17 is used to set the function of the multifunctional input AI3.

 The multifunctional input AI3 can only be set using parameter P17 if DIP switch no. 3 is set to OFF! The setting of DIP switches is described in section 10.

 The multifunctional input AI3 can only process analogue signals unlike inputs AI1 and AI2.

	Function	Standard	Min.	Max.	Unit
P17	Function of AI3 0 = Not used (input disabled) 1 = NTC outside air sensor 2 = NTC cold/hot water sensor (clip-on sensor) 3 = NTC cold water sensor (clip-on sensor) 4 = NTC hot water sensor 5 = NTC external room temperature sensor/air intake sensor 6 = 0..100 kOhm fan actuation 7 = 0..100 kOhm temperature setpoint 8 = 0..100V BMS winter/summer control 9 = 0..100V BMS winter control	0	0	9	

10.11 Functional testing of connected assemblies



The KaController provides the option of checking the function of the external units connected independently of the software application. The function of individual assemblies, such as the EC fan, can be directly activated and checked by means of inputs on the KaController.

The functional checks of the connected assemblies are called up and performed by the following operating steps:

1. Switch off the KaController by:
 - Pressing the ON/OFF key
 - or
 - Pressing the navigator for a minimum of 5 seconds
 - or
 - Turn the navigator to the left until OFF appears
2. Call up the Parameter menu by pressing the navigator dial for a minimum of 10 seconds. The display shows "Para" and then "CODE" with the value 000 in sequence.
3. Select the password (code) 77 by turning the navigator dial and confirm by pressing the navigator dial.
4. "L01" is shown on the display and the functional testing of the connected assemblies can start.

Important:

The individual test steps are called up by pressing the navigator dial. The default view with an "OFF" on-screen display is shown once the testing has been completed (L08).

Step	Input/Output	Display flashes	Display does not flash
L01*	Input AI1	Sensor faulty	Sensor OK
L02*	Input AI2	Sensor faulty	Sensor OK
L03*	Input AI3	Sensor faulty	Sensor OK
L04	Input DI1	Contact open	Contact closed
L05	Input DI2	Contact open	Contact closed
L06	Fault signal input	No alarm	Alarm pending
L07	Fan speed 0 – 10 V	--	Increased actuation Fan 0 V → 10 V
L08	Valve output V1	--	Output V1 activated
L09	Valve output 2	--	Output V2 activated

* The control automatically detects the requisite sensors on the analogue inputs AI1 - AI3 using the DIP switch settings. The respective display (L01-L03) flashes if sensors are faulty or not connected.



Observe hardware-related locks during functional testing (refer to the respective wiring diagram!)

10.12 Parameter list for control PCB

	Function	Standard	Min.	Max.	Unit	Comment
P000	Software version	-	0	255	-	-
P001	Base setpoint for setpoint entry \pm 3K	22	8	32	°C	32
P002	Switching on / off hysteresis for valves	3	0	255	K/10	1
P003	Neutral zone in a 4-pipe system (only in automatic mode)	3	0	255	K/10	3
P004	Cooling without fan assistance (natural convection)	0	0	255	K/10	0
P005	Heating without fan assistance (natural convection)	5	0	255	K/10	3
P006	Fan On/Off hysteresis (only in ventilation mode)	5	0	255	K/10	5
P007	P-band, heating	15	0	100	K/10	17
P008	P-band, cooling	20	0	100	K/10	20
P009	Offset to the base setpoint for setpoint input \pm 3K	3	0	10	K	0
P010	Clip-on sensor: limit temperature to activate fan stages 1 and 2 in heating mode	29	0	255	°C	29
P011	Clip-on sensor: Limit temperature to enable fan stages 3 and 4 in heating mode	31	0	255	°C	31
P012	Clip-on sensor: limit temperature to activate fan stage 5 in heating mode	33	0	255	°C	33
P013	Clip-on sensor: hysteresis for limit temperatures P010, P011, P012, P014	10	0	255	K/10	10
P014	Clip-on sensor: limit value temperature to activate the fan stages in cooling mode	18	0	255	°C	18
P015	Function of input AI1	0	0	19	-	0
P016	Function of input AI2	0	0	19	-	0
P017	Function of input AI3	0	0	9	-	0
P018	Temperature raising of cooling setpoint in Eco mode	30	0	255	K/10	30
P019	Temperature lowering of heating setpoint in Eco mode	30	0	255	K/10	30
P020	ADC limit coefficient	6	0	15	-	6
P021	ADC average coefficient	6	0	15	-	6
P022	Activation/disabling of sun symbol in Comfort mode	0	0	1	-	0
P023	Difference for compensation during cooling	0	-99	127	K/10	0
P024	Coefficient for compensation during heating	0	-20	20	1/10	0
P025	Difference for compensation during heating	0	-99	127	K/10	0
P026	Coefficient for compensation during heating	0	-20	20	1/10	0
P027	Fan setting: maximum run-time for manual fan mode	0	0	255	Min	0
P028	Flushing function: Fan stage during the flushing function	2	1	5	-	2
P029	Activation of continuous fan mode	0	0	1	-	1
P030	Ventilate temperature activation	12	0	255	°C	12
P031	Ventilation interval	27	0	255	°C	27
P032	Flushing function: maximum idle time of fan	15	0	255	Min	15
P033	Flushing function: duration of flushing function	240	0	255	s	240
P034	Flushing function: activation in operating modes	0	0	3	-	0
P035	Time the fan runs at Stage 1 after change of operating mode	0	0	255	s	0
P036	Type of setpoint setting	0	0	1	-	1
P037	Display	1	0	7	-	0
P038	Lock/disable function on control unit	64	0	255	-	105
P039	Function of digital output V2 (in 2-pipe system)	0	0	3	-	1
P040	Valve actuation by means of pulse width modulation	0	0	1	-	0
P041	Reset time of PI controller to actuate the fan in automatic fan mode	0	0	20	Min	0
P042	Fan setting: lock and activate fan stages	0	0	127	-	3
P043	Function of digital Input DI1	1	0	14	-	1

	Function	Standard	Min.	Max.	Unit	Comment
P044	Function of digital input DI2	0	0	14	-	2
P045	Threshold voltage for potentiometer, which switches on unit	10	0	100	kOhm	10
P046	Temperature setting corresponds to minimum resistance value = 10 kOhm in potentiometer	18	12	34	°C	18
P047	Temperature setting corresponds to maximum resistance value = 100 kOhm in potentiometer	24	13	35	°C	24
P048	Threshold voltage for potentiometer for starting up fans	10	0	100	kOhm	10
P049	Threshold voltage for potentiometer for maximum fan speed	90	0	100	kOhm	90
P050	Fan setting: max. fan speed	100	0	100	%	100
P051	Fan setting: min. fan speed	0	0	90	%	0
P052	Fan setting: speed limitation activated	0	0	1	-	0
P053	Valve actuation by pulse width modulation of valve switching cycle	15	10	30	Min	15
P054	Configuration of BUS system	0	0	2	-	0
P055	Display of heating/cooling symbols in Automatic mode	0	0	1	-	0
P056	DI2 setting (polarity) when DIP 4 = ON	1	0	1	-	1
P057	Reset setpoint setting to the value of P01 (after changing operating program)	0	0	1	-	0
P058	Sensor calibration: Sensor AI1	0	-99	127	K/10	0
P059	Reserved	-	-	-	-	-
P060	Reserved	-	-	-	-	-
P061	Sensor calibration: Sensor in the KaController	0	-99	127	K/10	0
P062	Sensor calibration: Sensor AI2	0	-99	127	K/10	0
P063	Reserved	-	-	-	-	-
P064	Sensor calibration: Sensor AI3	0	-99	127	K/10	0
P065	Reserved	-	-	-	-	-
P066	Master/Slave assignment in CANbus	0	0	1	-	0
P067	CANbus serial address	1	1	125	-	1
P068	Logic of idronic algorithms	0	0	7	-	0
P069	Network address	1	0	207	-	1
P070	Dependence of idronic algorithm (for slave units0	0	0	7	-	0
P071	Serial address of Slave 1	0	0	207	-	0
P072	Serial address of Slave 2	0	0	207	-	0
P073	Serial address of Slave 3	0	0	207	-	0
P074	Serial address of Slave 4	0	0	207	-	0
P075	Serial address of Slave 5	0	0	207	-	0
P076	Serial address of Slave 6	0	0	207	-	0
P077	Serial address of Slave 7	0	0	207	-	0
P078	Serial address of Slave 8	0	0	207	-	0
P079	Serial address of Slave 9	0	0	207	-	0
P080	Serial address of Slave 10	0	0	207	-	0
P081	Dependence of idronic algorithms Slave 1	0	0	7	-	0
P082	Dependence of idronic algorithms Slave 2	0	0	7	-	0
P083	Dependence of idronic algorithms Slave 3	0	0	7	-	0
P084	Dependence of idronic algorithms Slave 4	0	0	7	-	0
P085	Dependence of idronic algorithms Slave 5	0	0	7	-	0

	Function	Standard	Min.	Max.	Unit	Comment
P086	Dependence of idronic algorithms Slave 6	0	0	7	-	0
P087	Dependence of idronic algorithms Slave 7	0	0	7	-	0
P088	Dependence of idronic algorithms Slave 8	0	0	7	-	0
P089	Dependence of idronic algorithms Slave 9	0	0	7	-	0
P090	Dependence of idronic algorithms Slave 10	0	0	7	-	0
P091	Upload of default values	0	0	255	-	0
P092	Password management	0	0	255	-	0
P093	Type of pre-comfort (room occupancy)	0	0	3	-	0
P094	Pre-comfort timer	60	1	255	Min	60
P095	DIP switch settings switched off	0	0	1	-	0
P096	Reserved	-	-	-	-	-
P097	Reading of DIP switch	-	0	63	-	-
P098	Actuation 0..10V: switch on limit of valves	30	0	100	V/10	30
P099	Actuation 0..10V: switch on limit for min. fan speed	40	0	100	V/10	40
P100	Actuation 0..10V: switch on limit for max. fan speed	90	0	100	V/10	90
P101	Valve actuation by pulse width modulation of P-band in heating mode	15	0	100	K/10	15
P102	Valve actuation by pulse width modulation of P-band in cooling mode	15	0	100	K/10	15
P103	Valve actuation by pulse width modulation of reset time of PI controller	0	0	20	Min	0
P104	Minimum ON time with valve actuation PWM	3	0	20	Min	3
P105	Reserved	-	-	-	-	-
P106	Reserved	-	-	-	-	-
P107	Duration of valve open to check water temperature	5	0	255	Min	5
P108	Duration of valve closed	240	35	255	Min	240
P109	Reserved	-	-	-	-	-
P110	Reserved	-	-	-	-	-
P111	Reserved	-	-	-	-	-
P112	Reserved	-	-	-	-	-
P113	Reserved	-	-	-	-	-
P114	Reserved	-	-	-	-	-
P115	Reserved	-	-	-	-	-
P116	Reserved	-	-	-	-	-
P117	Locking operating functions (function keys on KaController)	0	0	7	-	0
P118	Reserved	-	-	-	-	-
P119	Reserved	-	-	-	-	-
P120	Reserved	-	-	-	-	-
P121	Reserved	-	-	-	-	-
P122	Reserved	-	-	-	-	-
P123	Reserved	-	-	-	-	-
P124	Reserved	-	-	-	-	-
P125	Reserved	-	-	-	-	-

10.13 KaController parameters

10.13.1 General

Specific user requirements can be enabled and disabled by means of parameter settings in the KaController, for instance the minimum and maximum setpoint temperature can be set using parameters in the KaController.

10.13.2 Calling up the Parameter menu



The following steps are needed to set the parameters:

1. Switch off the KaControl unit by:
 - Pressing the ON/OFF key
 - or
 - Pressing the navigator for a minimum of 5 seconds
 - or
 - Turn the navigator to the left until OFF appears
2. Call up the Parameter menu by pressing the navigator dial for a minimum of 10 seconds. The display shows "Para" and then "CODE" with the value 000 in sequence.
3. Select the password (code) 11 by turning the navigator dial and confirm by pressing the navigator dial. You are now in the KaController's Parameter menu,
4. Parameters can now be set using the navigator.

Setting parameters:

- Turn the navigator dial to select the parameter.
- Press the navigator dial to call up Edit mode.
- Set the required value by turning the navigator dial.
- Press the navigator dial to save the new value.

There are 3 options to exit the Parameter menu and call up the standard view:

- If no action has been carried out using the navigator dial for longer than 2 minutes.
- Hold down the navigator dial for 5 seconds.
- Turn the navigator dial, select "ESC" on the display and confirm the selection by pressing the navigator dial.

10.13.3 KaController parameter list

	Function	Standard	Min.	Max.	Unit	Comment
t001	Serial address	1	0	207	-	
t002	Baud rate 0 = Baud rate 4800 1 = Baud rate 9600 2 = Baud rate 19200	2	0	2	-	
t003	Background lighting function 0 = Slow fade in, fast fade out 1 = Slow fade in, slow fade out 2 = Fast fade in, fast fade out	0	0	2	-	
t004	Strong background lighting	4	0	5	-	
t005	Sensor calibration of KaController sensor	0	-60	60	°C	
t006	LCD display contrast	15	0	15	-	
t007	BEEP setting 0 = BEEP ON 1 = BEEP OFF	0	0	1	-	
t008	Password for KaController Parameter menu	11	0	999	-	
t009	Minimum settable setpoint temperature	8	0	20	°C	
t010	Maximum settable setpoint temperature	35	10	40	°C	
t011	Interval of setpoint setting 0 = Automatic setting based on PCB (parameterisable, freely programmable) 1 = Increment of 1°C (parameterisable PCBs) 2 = Increment of 0.5 °C (freely programmable PCBs)	0	0	2	-	
t012	Date/Time setting: Year	9	0	99	-	
t013	Date/Time setting: Month	1	1	12	-	
t014	Date/Time setting: Day	1	1	31	-	
t015	Date/Time setting: Weekday	1	1	7	-	
t016	Date/Time setting: Hour	0	0	23	-	
t017	Date/Time setting: Minute	0	0	59	-	

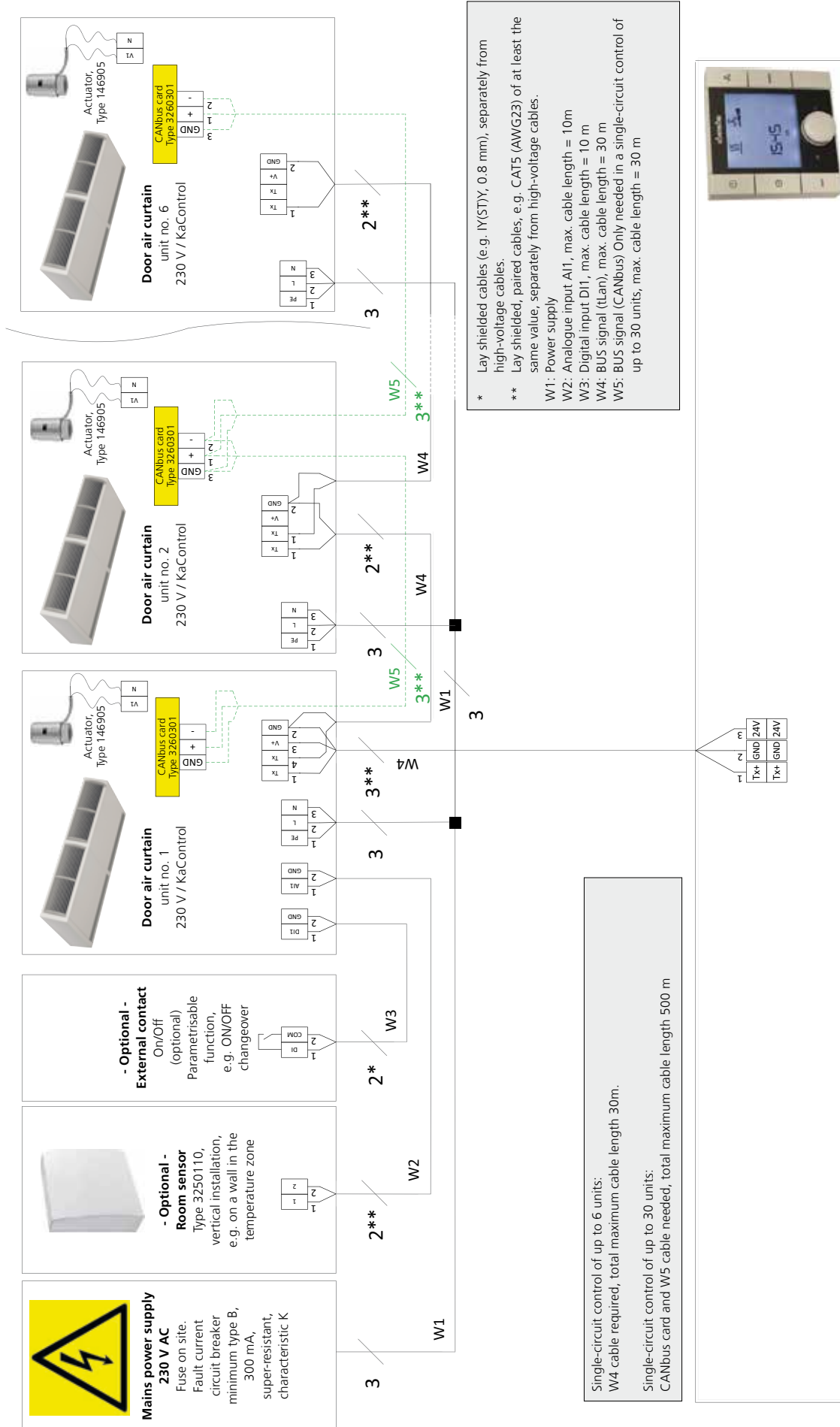

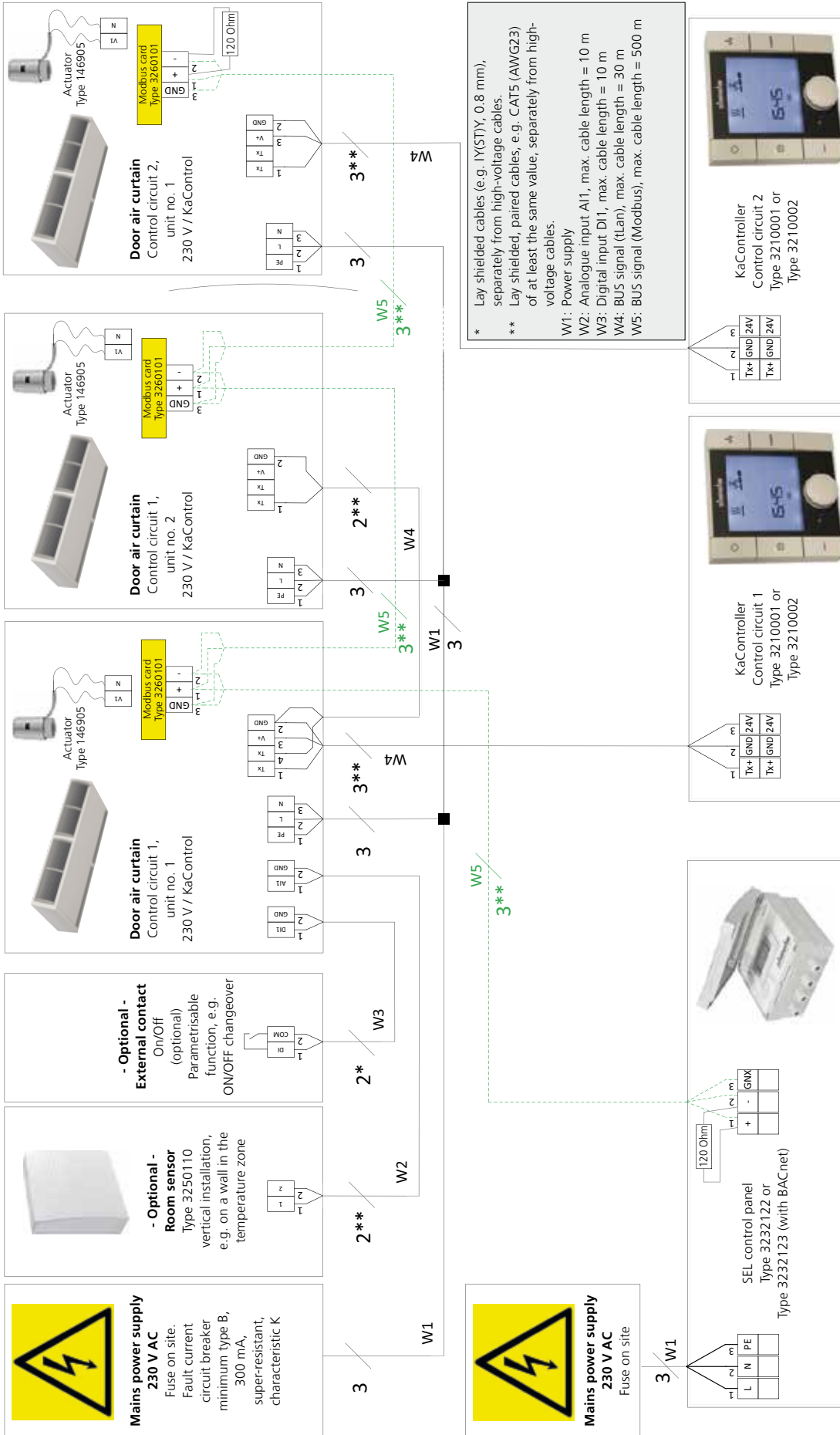

* Lay shielded cables (e.g. IY(STY), 0.8 mm), separately from high-voltage cables.
 ** Lay shielded, paired cables, e.g. CAT5 (AWG23) of at least the same value, separately from high-voltage cables.
 W1: Power supply
 W2: Analogue input AI1, max. cable length = 10 m
 W3: Digital input DI1, max. cable length = 10 m
 W4: BUS signal (ILan), max. cable length = 30 m
 W5: BUS signal (Modbus), max. cable length = 500 m



Kampmann.co.uk/installation_manuals

Kampmann GmbH
Friedrich-Ebert-Str. 128 - 130
49811 Lingen (Ems)
Germany

T +49 591 7108-660
F +49 591 7108-173
E export@kampmann.de
W Kampmann.eu

Kampmann UK Ltd.
Dial House, Govett Avenue
Shepperton, Middlesex, TW17 8AG
Great Britain

T +44 (0)1932 228592
F +44 (0)1932 228949
E info@kampmann.co.uk
W Kampmann.co.uk